



CURTIS

Instrumentation



Color Vehicle Instruments

enGage® VI & VII



Can Color Instrument

The Curtis enGage® VI & VII display is a microprocessor based, programmable, CAN compatible instrument with full Input/Output capability and can be used to display information in a wide variety of on- and off-road electric vehicle applications, including material handling, industrial, utility, and recreational. The Curtis enGage™ VI and VII color displays differentiate your industrial vehicle by providing meaningful system information in vibrant color when you need it. With the ability to display video from cameras and controller data, diagnostics and error codes, the enGage™ VI and VII are the easy-to-integrate, reliable and highly functional solution to your vehicle needs.

See a 360° view of the enGage VI and VII at:

curtisinstruments.com/360view

FEATURES

Exceptional LCD

- ▶ Large and sharp, easy-to-read, high-resolution LCD screen for optimum viewing.
- ▶ Integrates comprehensive panel functionality into a single display to differentiate and enhance vehicle aesthetics.
- ▶ Rich, vivid colors, sharp imagery, strong contrast and high-color vibrancy allow the perfect palette for designing virtually any custom screen according to your application and requirements.
- ▶ Allows state-of-the-art design flexibility and progressive appearance.
- ▶ Instrument designers benefit from a beautiful and effective array of graphic capabilities, colors, shapes and lines.
- ▶ Screen customization flexibility is virtually limitless.
- ▶ Transflective LCD for clear viewing even in bright sunlight.
- ▶ Clear, crisp color LCD — 1/4 VGA, 320 x 240 (3.5" for Model 3601, 5.7" for Model 3701).
- ▶ Two color video inputs, both of which accept NTSC or PAL format.
- ▶ Message center, display menu system, password security options provide flexible and varied options to vehicle panel designers.

Universal CAN Compatibility

- ▶ Seamlessly integrates with Curtis AC vehicle speed controllers and input devices without requiring additional code to be written.
- ▶ Fully CAN compatible—CANopen.
- ▶ Interacts with any CAN node on your vehicle network.
- ▶ Options include isolated CANbus interface and an affordable CAN-only version, without the I/O feature.



enGage® VI: 3.5" QVGA Color Display
& enGage® VII: 5.7" QVGA Color Display
Shown Cased

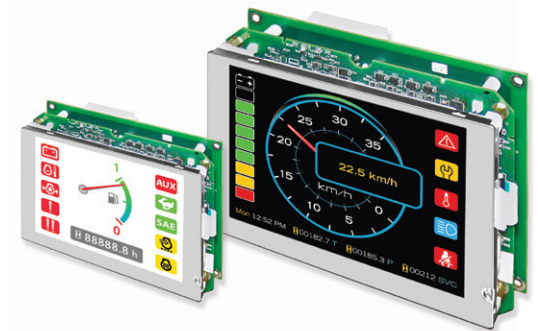

enGage® VI & VII Module Only



enGage® VII with Optional Camera



Can Color Instrument

FEATURES continued

Wide Ranging I/O

- ▶ Powerful I/O capability allows for easy system integration.
- ▶ Non-CAN based digital and analog device signals in your distributed network can be converted to CAN.
- ▶ Significantly reduces the wiring requirements through the use of CANopen.
- ▶ Independent, open-drain MOSFET outputs rated 2A continuous (2 for Model 3601, 4 for Model 3701).

Powerful Customization & Programmability

- ▶ The enGage® VI & VII is a blank palette that allows the vehicle OEM to design a unique, special and fully customized panel fully suited to the application, with complete flexibility to match the instrument to the vehicle's display requirements.
- ▶ One single screen displays many functions and instrument readings based on OEM defined functional and operational system parameters and thresholds.
- ▶ Changing display parameters (i.e. maintenance parameters, time of day, etc.) and providing input (i.e. password, check list information) can be accomplished through button inputs.
- ▶ The enGage® VI & VII can be programmed with the proprietary Curtis Vehicle Control Language (VCL) from a Curtis AC controller.

Cased Unit Features

- ▶ Efficient, minimally intrusive case design for optimal use of available panel space.
- ▶ Easy "snap fit" hardware free mounting allows low installation cost and eliminates loose hardware.
- ▶ Integrated front panel gasket provides sealing between the instrument and panel, preventing moisture/dust through the panel opening.
- ▶ IP67 rated front and rear effective for a wide variety of environmental conditions.
- ▶ Rugged, heavy duty Deutsch connectors (sealed DTM series) provide reliable connections in harsh environments.
- ▶ Anti-fog/anti-glare treated, scratch-resistant, chemically strengthened glass (plastic optional) lens provides superior viewing in all environmental conditions.

Additional Advantages

- ▶ Real time clock can be used to provide data logging and real-time event time stamping.
- ▶ Greatly reduces secondary displays, circuits, systems, installation and support electronics costs.
- ▶ LCD heater option allows operation in cold climates to -40°C (normal operation to -20°C without heater).
- ▶ Wide voltage range, 12-48VDC or 60-144VDC.
- ▶ Integral audible alarm output.
- ▶ Available with the newest Curtis battery discharge algorithm for highly accurate battery state of charge information.

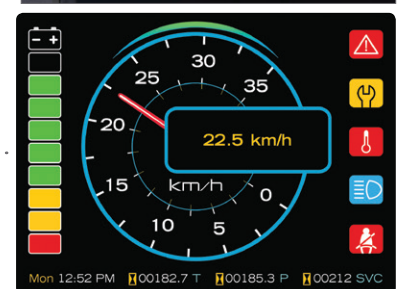
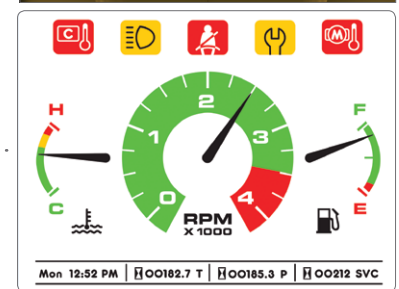



Can Color Instrument

SPECIFICATIONS

Environmental

Temperature Range

Operating: -40°C to +70°C

Storage: -40°C to +85°C

Cycling: Per SAE J1455 section 4.1.3.1

Shock: Per SAE J1455 section 4.1.3.2

NOTE: Deviation from SAE J1455 Aug. 95, section 5.2.1.1 maximum temperature of +85°C due to LCD module limitations. At temperatures below 0°C, the LCD heating element turns on to prevent slow display response times.

Humidity

Applicable to enclosed units only: 95% RH (non-condensing) at +38°C as per SAE J1455 Aug. 94, section 4.2.3.

Water / Dust Ingress

Applicable to enclosed units only: sealed front and rear to IP67. For models that include video option, video connector must be installed to achieve IP67 rating on rear of unit.

Anti-fog Lens

Applicable to enclosed units only.

Lens Scratch Resistance

Applicable to enclosed units only: standard is Chemically Strengthened Glass w/Anti-Glare and Anti-Fog coatings. Optional Hard-Coated Polycarbonate Lens available, which meets the Bayer and Steel wool abrasion tests.

Salt Spray Resistant Lens (Fog)

Applicable to enclosed units only.

Shock

Applicable to enclosed units only: meets SAE J1378 July 98: Amplitude 44–55g, half sine, 9–13 ms duration.

Vibration

Applicable to enclosed units only: Meets SAE J1378 July 98. Double amplitude of 1.53 mm, with frequency sweep from 10-80-10 Hz (20g max.) at intervals of 1 minute.





Can Color Instrument

SPECIFICATIONS continued

EMC Specifications

Emissions

Designed to meet EN61000-6-4:2007.

Immunity

Designed to meet the following:

- ▶ SAE J1455 section 4.11.2.2.1 & 4.11.2.2.2
- ▶ EN61000-6-2:2005, EN61000-4-2:1995
- ▶ EN61000-4-3:2006, EN61000-4-4:2004, EN61000-4-5:2006
- ▶ EN61000-6-4:2007

Safety

Meets EN 61010-1: 2001 Part 1: General safety requirements for measurement, control and laboratory use.

Regulatory Approvals

- ▶ RoHS Compliant
- ▶ CE Mark (pending)
Tested to meet the Low Voltage Directive (LVD) 2006/95/EC and EMC Directive 2004/108/EC. Product specification will be updated upon completion of testing.
- ▶ UL Mark (pending)
Product specification will be updated upon completion of testing.

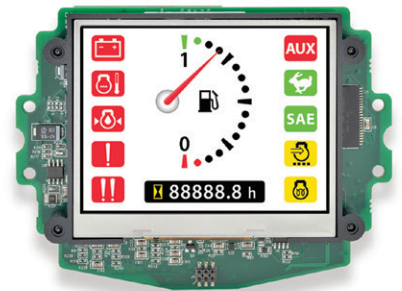
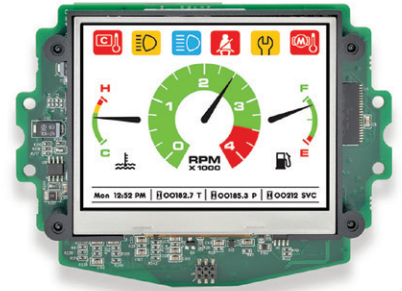



Can Color Instrument

MODEL ENCODEMENT

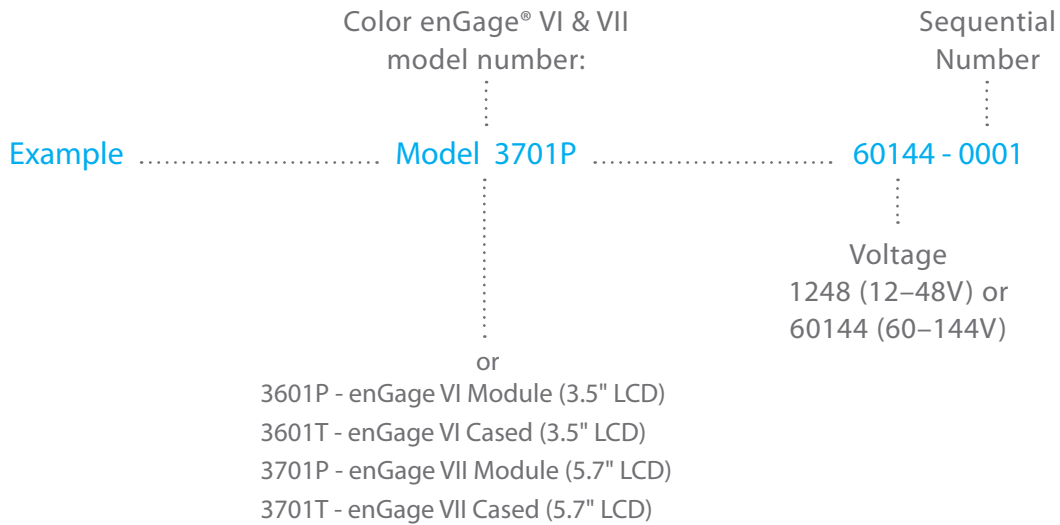

NOTE: All modules are supplied with critical components exposed. If the module is being used in an environment other than specified, the user must take precautions to package the module to provide adequate protection.

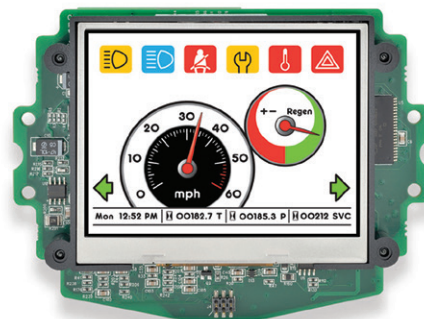
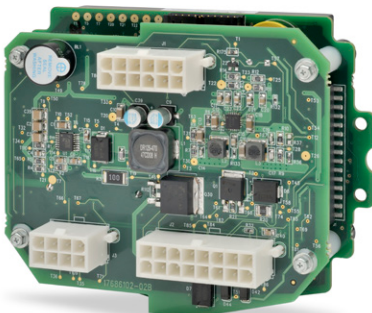
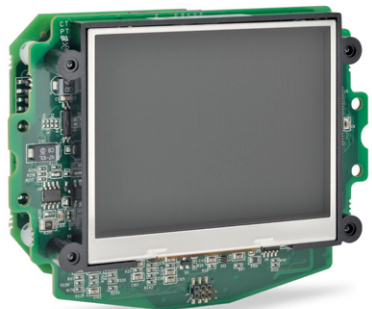



Can Color Instrument

DIMENSIONS

Recommended Panel Cutout Dimensions mm

enGage VII = (e7) dimensions in blue

enGage VI = (e6) dimensions in green

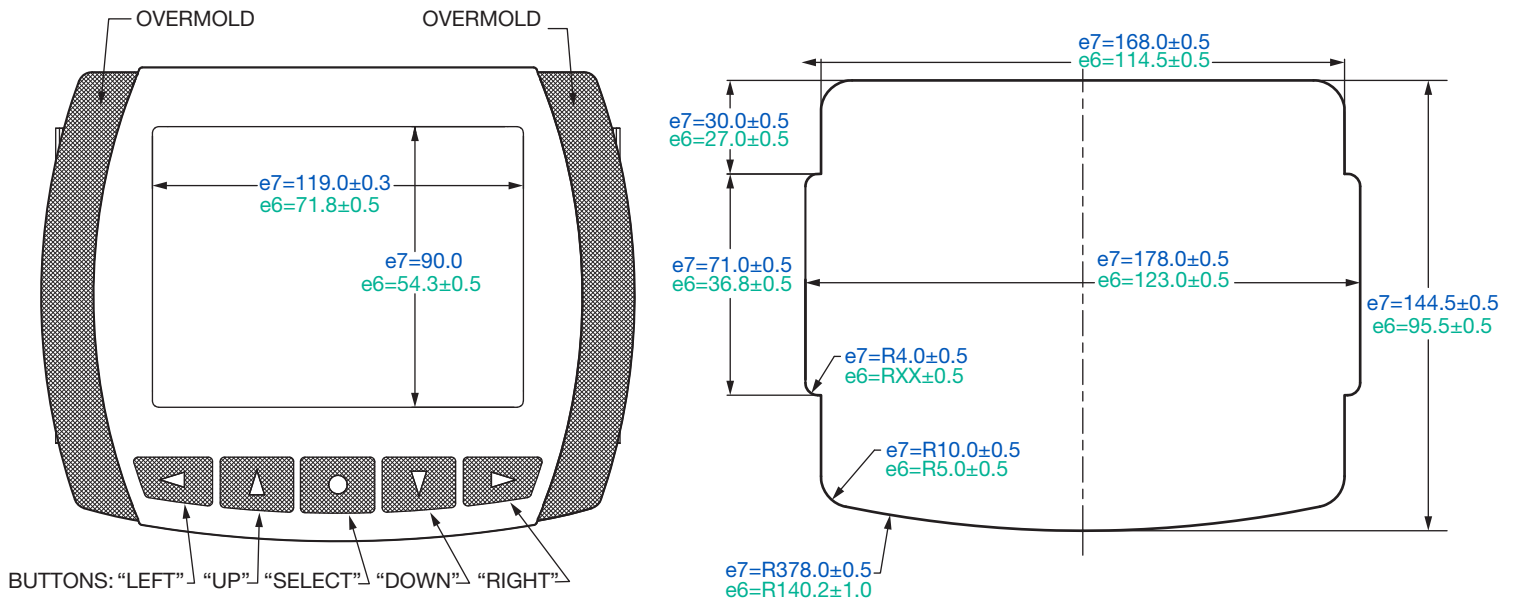

Mounting Options

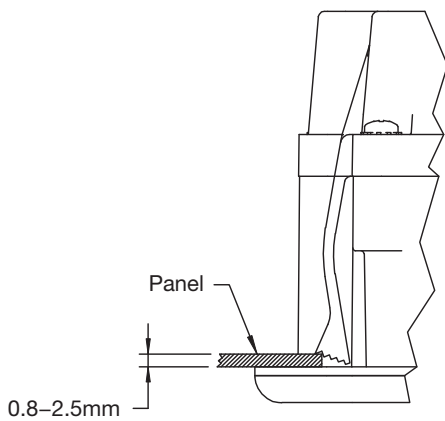

FIGURE 1

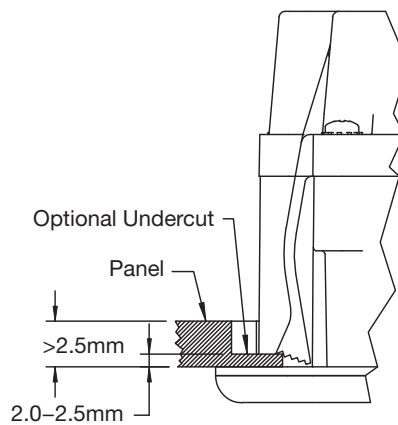

FIGURE 2

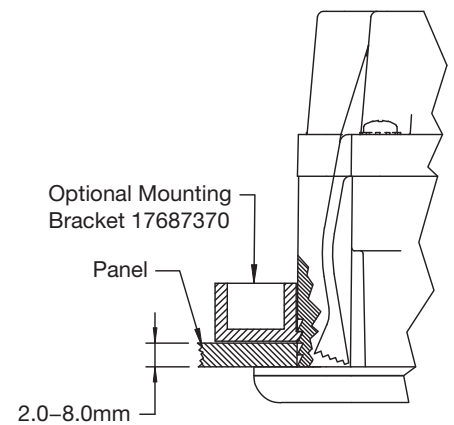

FIGURE 3



Can Color Instrument

3601 P Dimensions mm

FRONT

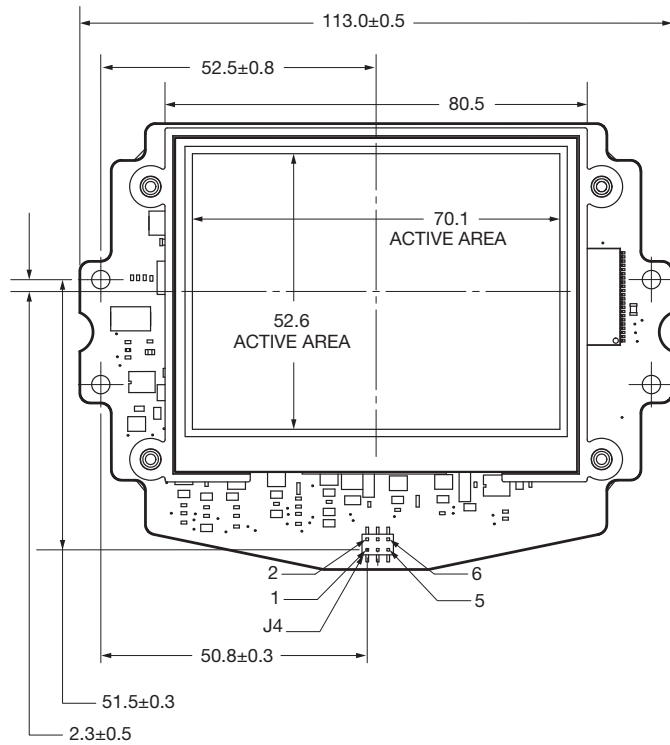

SIDE

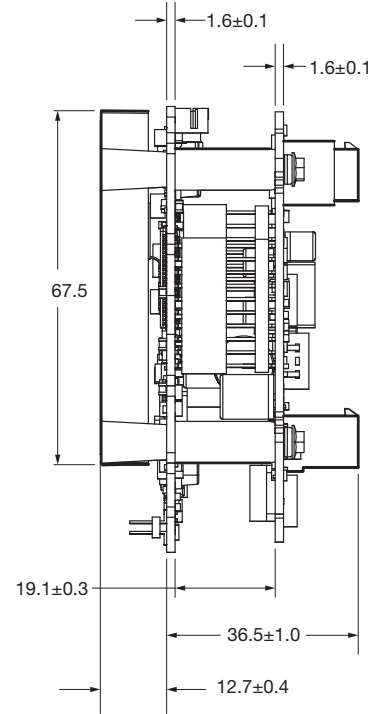

BACK

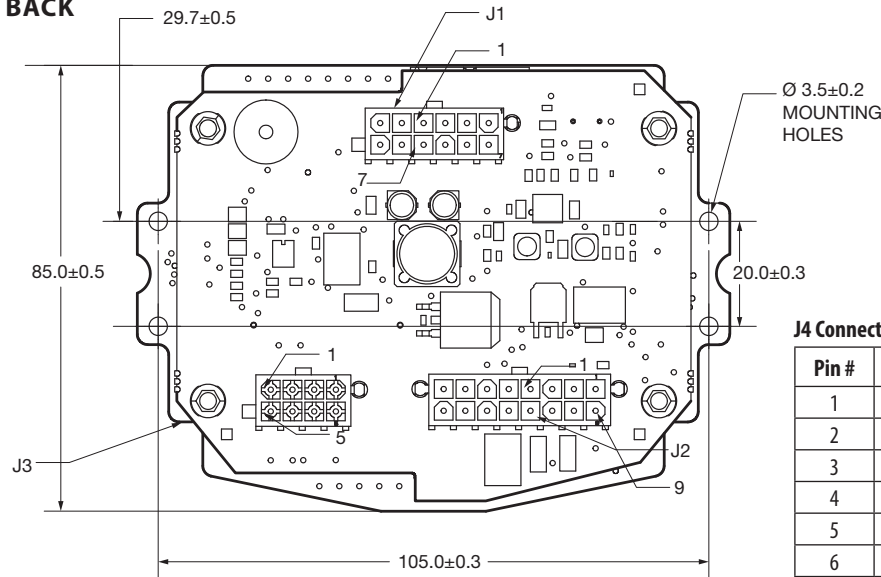

J1 Connect

Pin #	Description
1	Battery Voltage (B+) – See Note 4
2	Battery Common (B–)
3	Keyswitch
4	CAN High
5	CAN Low
6	CAN Shield
7	CAN Term. 1 – See Note 6
8	CAN Term. 2 – See Note 6
9	1311 Rx
10	CAN Common
11	1311 Tx
12	LCD Heater – See Note 5

J2 Connect

Pin #	Description
1	Sender 1
2	N/C
3	Switch Input 1
4	Switch Input 2
5	Switch Input 3
6	Switch Input 4
7	BDI Range Input
8	Backlight Dimmer Input
9	Frequency Input 1
10	MOSFET Output 1
11	MOSFET Output 2
12	MOSFET Return See Note 9
13	Switch Input 5
14	Switch Input 6
15	Switch Input 7
16	Switch Input 8

J3 Connect

Pin #	Description
1	MOSFET 3 & 4 Return– See Note 10
2	N/C
3	Video Input 1
4	Video Input Ground
5	Frequency Input 2
6	N/C
7	Video Input Ground
8	Video Input 2

J4 Connect

Pin #	Description
1	Switch Common
2	Pushbutton 1 (Left)
3	Pushbutton 2 (Up)
4	Pushbutton 3 (Select)
5	Pushbutton 4 (Down)
6	Pushbutton 5 (Right)

NOTES:

- Mounting: (4) Holes 3.6 mm dia.
- LCD: Color, 320x240 (QVGA) Resolution, 70.1x52.6 mm Active Area.
 - Cased units include lens with anti-reflective coating.
 - Wide viewing angle: 100 deg vertical, 120 deg horizontal.
- Mating Connectors:
 - J1 - AMP 770581-1, Pins 770904-1;
 - J2 - AMP 770583-1, Pins 770904-1;
 - J3 - AMP 770579-1, Pins 770904-1;
 - J4 - MOLEX 51110-0650, Pins 50394;
- Battery Voltage (B+) to be protected by a 1 AMP fuse.
- LCD Heater B+ to be protected by a 3 AMP fuse.
- Connect CAN Term 1 to CAN Term 2 for 120 OHM CAN Bus Termination.
- All modules are designed to be incorporated into a higher level assembly. The user is responsible for providing the environmental protection and mechanical support required to meet the specifications of that higher level assembly.
- B+ Operating Range: 12–48 models, 9–60VDC, 60–144VDC, 45–180VDC.
- Sender input range: 0–10V.
- MOSFET Returns MUST be connected to B–.



Can Color Instrument

3601T Dimensions mm

FRONT

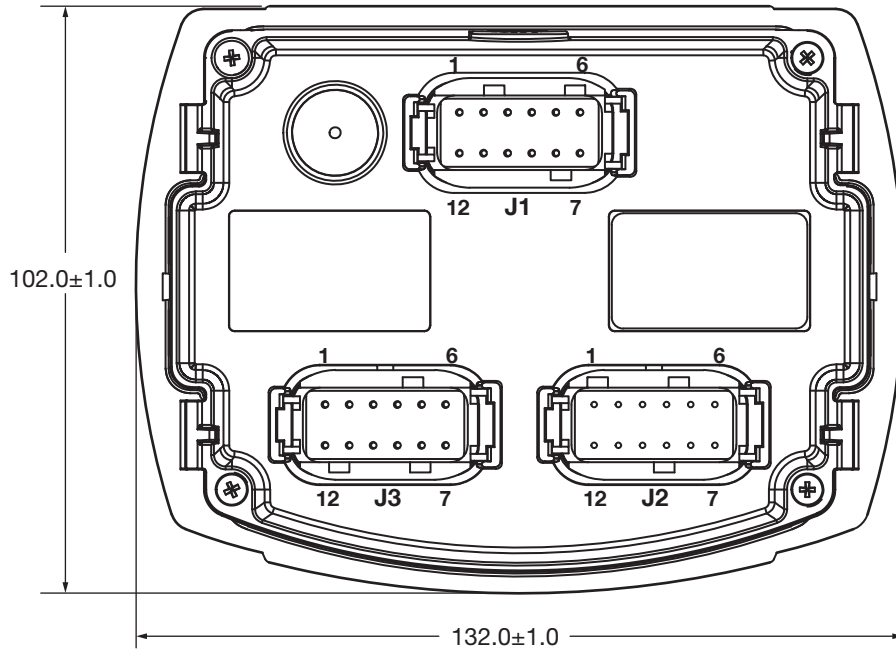

SIDE

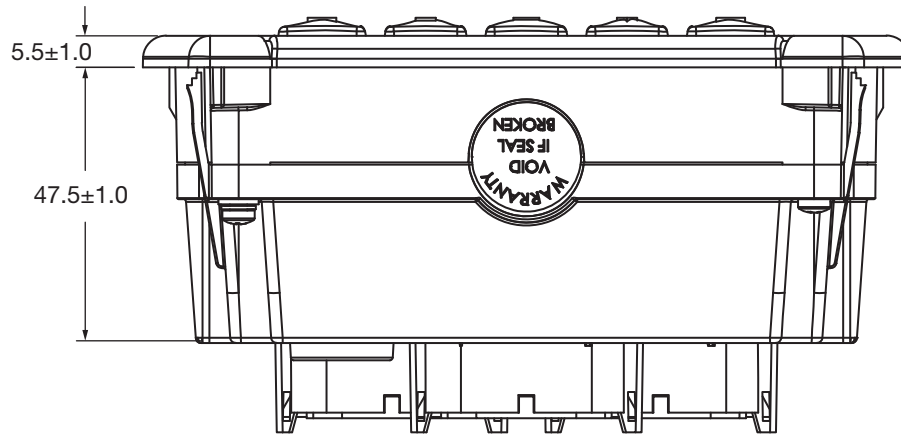

NOTES:

- Materials:
 - Case: ABS/Polycarbonate, Gray, UL94-V0.
 - Lens: Polycarbonate, Clear, Scratch-resistant, anti-reflective outer surface, anti-fog inner surface.
 - Buttons and Overmold: Black rubber.
- Mounting: Use snap fingers on panel thickness from 1.5 mm to 2.5 mm. Mounting bracket 17686370 can be used for panel thicknesses 1.5–6.0mm. Mounting bracket is designed for one installation only. Destruction of mounting bracket may occur if attempted to remove.
- LCD: Color, 320x240 (QVGA) resolution, 70.1x52.6mm viewing area. Wide viewing angle: verticle 100 deg, horizontal 120 deg.
- Mating Deutsch Connectors: J1 - DTM06-12SA, Housing; J2 - DTM06-12SB, Housing; J3 - DTM06-12SC, Housing; J4 - DTM06-12SD, Housing; Contacts - 0462-201-20141 or 1062-20-0122 Sockets. Wedge Lock - WM-12S. See Pinout charts.
- Battery Voltage (B+) to be protected by 1 amp fuse.
- LCD Heater B+ to be protected by 3 amp fuse.
- Connect CAN term 1 to CAN term 2 for 120 Ohm CAN bus termination.
- B+ Operating Range: 3601T 1248-XXXX: 9-60V
3601T 60144-XXXX: 45-180V.
- Sender Input Range: 1-10V.
- MOSFET Return must be connected to B-.
- Protection Rating IP67.

J1 Connect

Pin #	Description
1	Battery Voltage (B+) – See Note 5
2	Battery Common (B-)
3	Keyswitch
4	CAN High
5	CAN Low
6	CAN Shield
7	CAN Term. 1 – See Note 7
8	CAN Term. 2 – See Note 7
9	1311 Rx
10	CAN Common
11	1311 Tx
12	LCD Heater B+ – See Note 6

J2 Connect

Pin #	Description
1	Sender 1
2	N/C
3	Switch Input 1
4	Switch Input 2
5	Switch Input 3
6	Switch Input 4
7	N/C
8	Backlight Dimmer Input
9	Frequency Input 1
10	MOSFET Output 1
11	MOSFET Output 2
12	MOSFET 1 & 2 Return – See Note 10

J3 Connect

Pin #	Description
1	Switch Input 5
2	Switch Input 6
3	Switch Input 7
4	Switch Input 8
5	Sender 2
6	N/C
7	N/C
8	Frequency Input 2
9	Video Input 1
10	Video Input Ground
11	Video Input 2
12	Video Input Ground



Can Color Instrument

3701P Dimensions mm

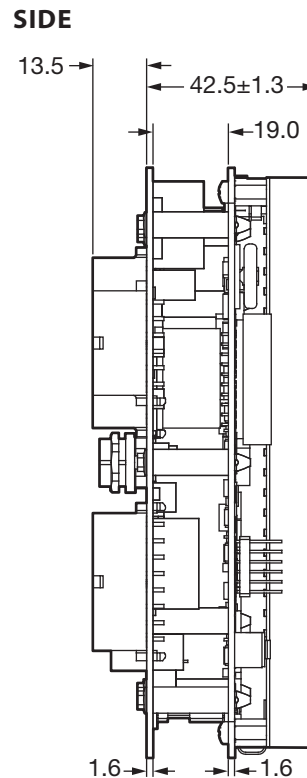
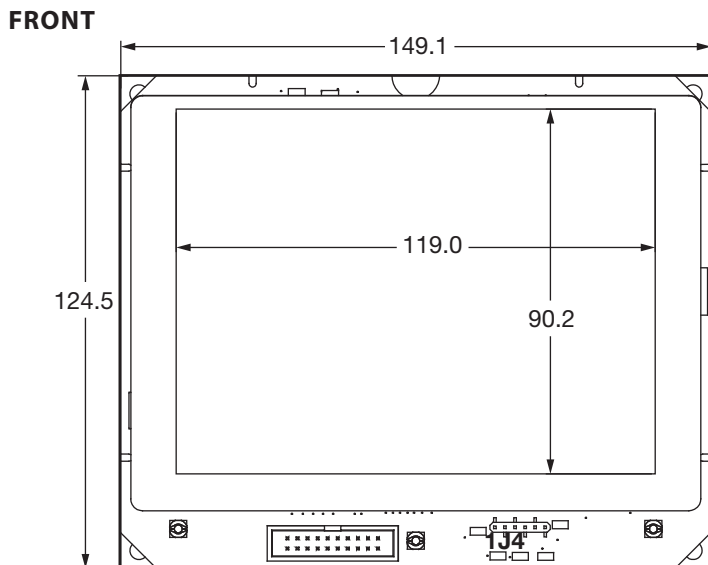
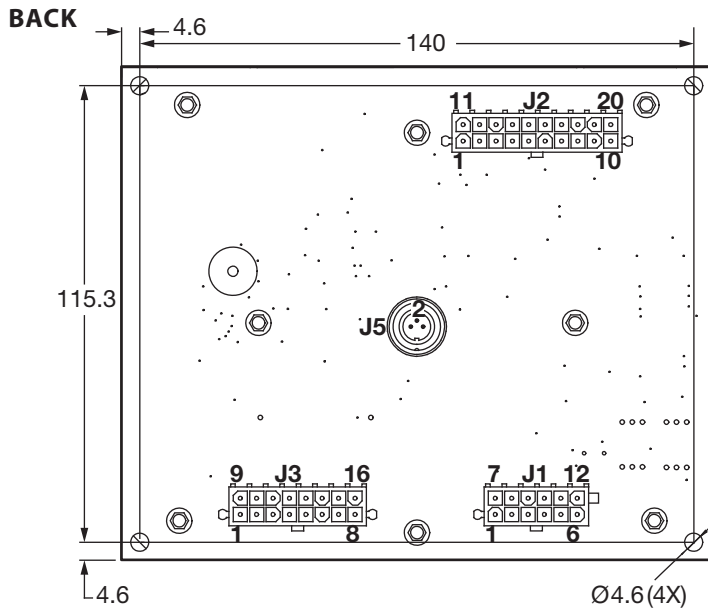

J1 Connect

Pin #	Description
1	Battery Voltage (B+) – See Note 4
2	Battery Common (B–)
3	Keyswitch
4	CAN High
5	CAN Low
6	CAN Shield
7	CAN Term. 1 – See Note 6
8	CAN Term. 2 – See Note 6
9	1311 Rx
10	CAN Common
11	1311 Tx
12	LCD Heater B+ – See Note 5

J2 Connect

Pin #	Description
1	Sender 1
2	N/C
3	Switch Input 1
4	Switch Input 2
5	Switch Input 3
6	Switch Input 4
7	BDI Range Select
8	Backlight Dimmer Input
9	Frequency Input 1
10	MOSFET Output 1
11	MOSFET Output 2
12	MOSFET 1 & 2 Return
13	Switch Input 5
14	Switch Input 6
15	Switch Input 7
16	Switch Input 8
17	Sender 2
18	N/C
19	Sender 3
20	Frequency Input 2 – See Note 10

J3 Connect

Pin #	Description
1	MOSFET 3 & 4 Return – See Note 10
2	Frequency Input 3
3	MOSFET Output 3
4	MOSFET Output 4
5	Switch Input 9
6	Switch Input 10
7	Switch Input 11
8	Switch Input 12
9	Switch Input 13
10	Switch Input 14
11	Switch Input 15
12	Switch Input 16
13	Sender 4
14	Potentiometer High
15	Sender 5
16	Potentiometer Low

J4 Connect

Pin #	Description
1	Ground
2	Pushbutton 1 (Left)
3	Pushbutton 2 (Up)
4	Pushbutton 3 (Select)
5	Pushbutton 4 (Down)
6	Pushbutton 5 (Right)

J5 Connect

Pin #	Description
1	Video Input Ground
2	Video Input Signal 1
3	Video Input Signal 2

NOTES:

- Mounting: (4) Holes 3.6 mm dia.
- LCD: Color, 320x240 (QVGA) Resolution, 115.2x86.4 mm Active Area.
 - Cased units include lens with anti-reflective coating.
 - Wide viewing angle: 120 deg vertical, 140 deg horizontal.
- Mating Connectors:
 - J1 - AMP 770581-1, Pins 770904-1;
 - J2 - AMP 770585-1, Pins 770904-1;
 - J3 - AMP 770583-1, Pins 770904-1;
 - J4 - AMP 103975-5;
 - J5 - Binder 99-0405-00-03 (Unshielded) or 99-0405-10-03 (Shielded).
- Battery Voltage (B+) to be protected by a 1 AMP fuse.
- LCD Heater B+ to be protected by a 3 AMP fuse.
- Connect CAN Term 1 to CAN Term 2 for 120 OHM CAN Bus Termination.
- All modules are designed to be incorporated into a higher level assembly. The user is responsible for providing the environmental protection and mechanical support required to meet the specifications of that higher level assembly.
- B+ Operating Range: 12–48 models, 9–60VDC, 60–144VDC, 45–180VDC.
- Sender input range: 0–10V.
- MOSFET Returns MUST be connected to B–.
- Unless otherwise specified, tolerance is +/- 0.5.



Can Color Instrument

3701T Dimensions mm

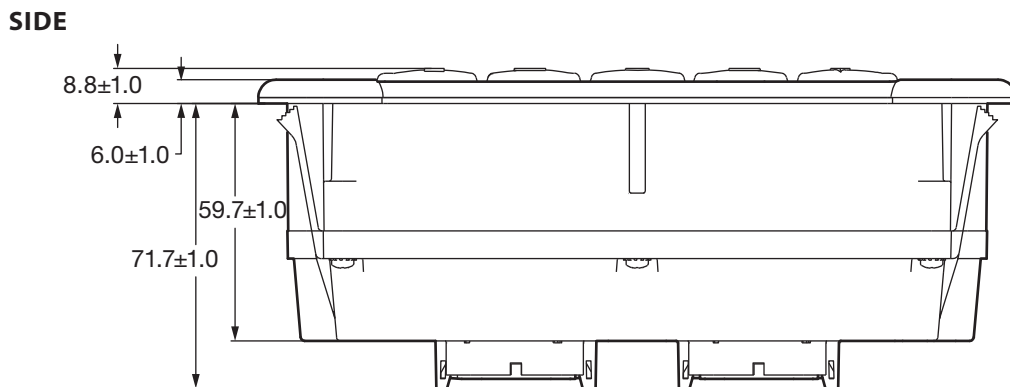
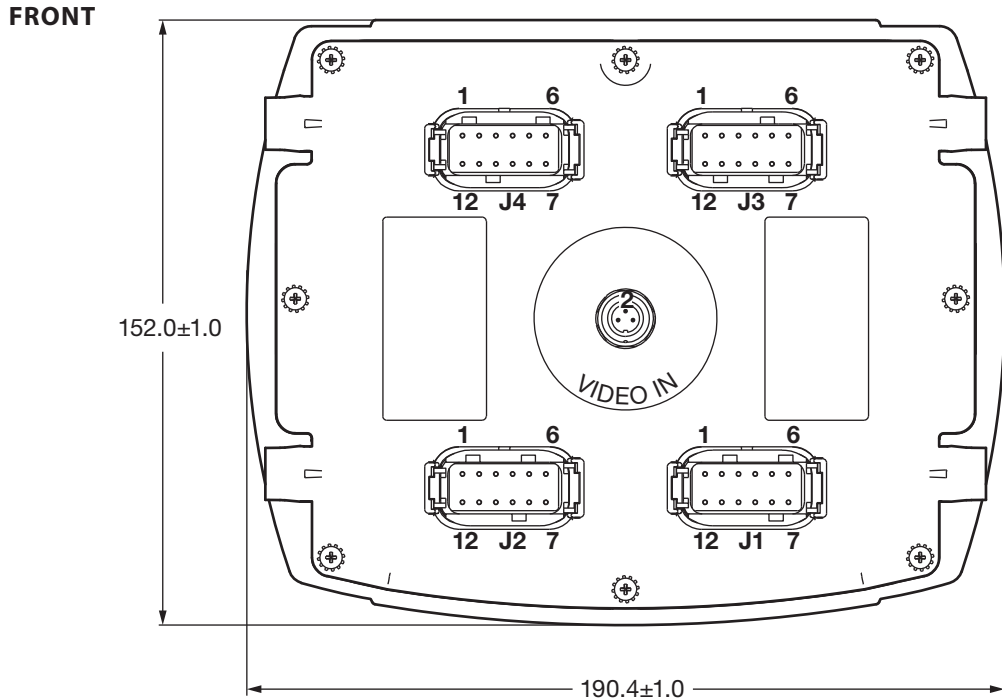

J1 Connect

Pin #	Description
1	Battery Voltage (B+) – See Note 6
2	Battery Common (B–)
3	Keyswitch
4	CAN High
5	CAN Low
6	CAN Shield
7	CAN Term. 1 – See Note 8
8	CAN Term. 2 – See Note 8
9	1311 Rx
10	CAN Common
11	1311 Tx
12	LCD Heater B+ – See Note 7

J2 Connect

Pin #	Description
1	Sender 1
2	N/C
3	Switch Input 1
4	Switch Input 2
5	Switch Input 3
6	Switch Input 4
7	BDI Range Select
8	Backlight Dimmer Input
9	Frequency Input 1
10	MOSFET Output 1
11	MOSFET Output 2
12	MOSFET 1 & 2 Return

J3 Connect

Pin #	Description
1	Switch Input 5
2	Switch Input 6
3	Switch Input 7
4	Switch Input 8
5	Sender 2
6	N/C
7	Sender 3
8	Frequency Input 2
9	MOSFET 3 & 4 Return
10	Frequency Input 3
11	MOSFET Output 3
12	MOSFET Output 4

J4 Connect

Pin #	Description
1	Switch Input 9
2	Switch Input 10
3	Switch Input 11
4	Switch Input 12
5	Switch Input 13
6	Switch Input 14
7	Switch Input 15
8	Switch Input 16
9	Sender 4
10	Potentiometer High
11	Sender 5
12	Potentiometer Low

Video In

Pin #	Description
1	Input Ground
2	Input Signal 1
3	Input Signal 2



Can Color Instrument

ACCESSORIES

Video Splitter



- ▶ Curtis part number 18427113 camera splitter box allows direct connection between two cameras and Model enGage VII.
- ▶ Cameras are also available: PAL format – Curtis part number 17760PAL-001, NTSC format – Curtis part number 17760NTSC-001.

enGage VI and VII NOTES:

1. Materials:
 - a. Case: ABS/Polycarbonate, Gray, UL94-V0.
 - b. Lens: Glass, Clear, Scratch-resistant, anti-reflective outer surface, anti-fog inner surface. Polycarbonate lens material optional.
 - c. Buttons and Overmold: Black rubber.
2. Mounting: Use snap fingers on panel thickness from 0.8 mm to 2.5 mm .
3. Mounting bracket 17687370 can be used for panel thicknesses 2.0–8.0mm. Mounting bracket is designed for one installation only. Destruction of mounting bracket may occur if attempted to remove (See “Mounting Options” on Page 7).
4. LCD: Color, 320x240 (QVGA) resolution, 115.2x86.4mm viewing area. Wide viewing angle: verticle 120 deg, horizontal 140 deg.
5. Mating Deutsch Connectors:
 - J1 - DTM06-12SA, Housing;
 - J2 - DTM06-12SB, Housing;
 - J3 - DTM06-12SC, Housing
 - J4 - DTM06-12SD, Housing;
 Contacts - 0462-201-20141 or 1062-20-0122 Sockets.;
 Wedge Lock - WM-12S;
 See Pinout charts above.
6. Mating “Video In” Connector: Binder 99-0405-00-03 (Unshielded) or 99-0405-10-03 (Shielded). See Pinout charts above.
7. Battery Voltage (B+) to be protected by 1 amp fuse.
8. LCD Heater B+ to be protected by 3 amp fuse.
9. Connect CAN term 1 to CAN term 2 for 120 Ohm CAN bus termination.
10. MOSFET returns must be connected to B–.
11. Mating harness part numbers:
 - Connector J1: 15233014-1;
 - Connector J2: 15233014-2;
 - Connector J3: 15233014-3;
 - Connector J4: 15233014-4.

WARRANTY Two year limited warranty from time of delivery.

The Curtis Difference 
 You feel it when you drive it



is a trademark of Curtis Instruments, Inc.

Specifications subject to change without notice

©2016 Curtis Instruments, Inc.

50192 REV H 2/16