



1551 S. Vineyard Avenue
Ontario, CA 91761
(909) 923-1973

WIRING SCHEMATICS

**FOR SOFTWARE VERSIONS UP TO AND INCLUDING
GENERIC 318**

ON-ROAD VEHICLE CONVERSION

**REVISION: B6
Date: 2/19/2013**

NOTICE: This drawing is the property of Hi Performance Electric Vehicle Systems, Inc. and/or its subsidiaries and affiliates (individually and collectively "HPEVS"), and contains highly proprietary, confidential, and trade secret information of HPEVS. The recipient of this drawing agrees (a) to use the information contained herein for the purpose for which it was furnished by HPEVS (b) to return this drawing upon HPEVS request. This notice shall appear on any complete or partial reproduction of this drawing.

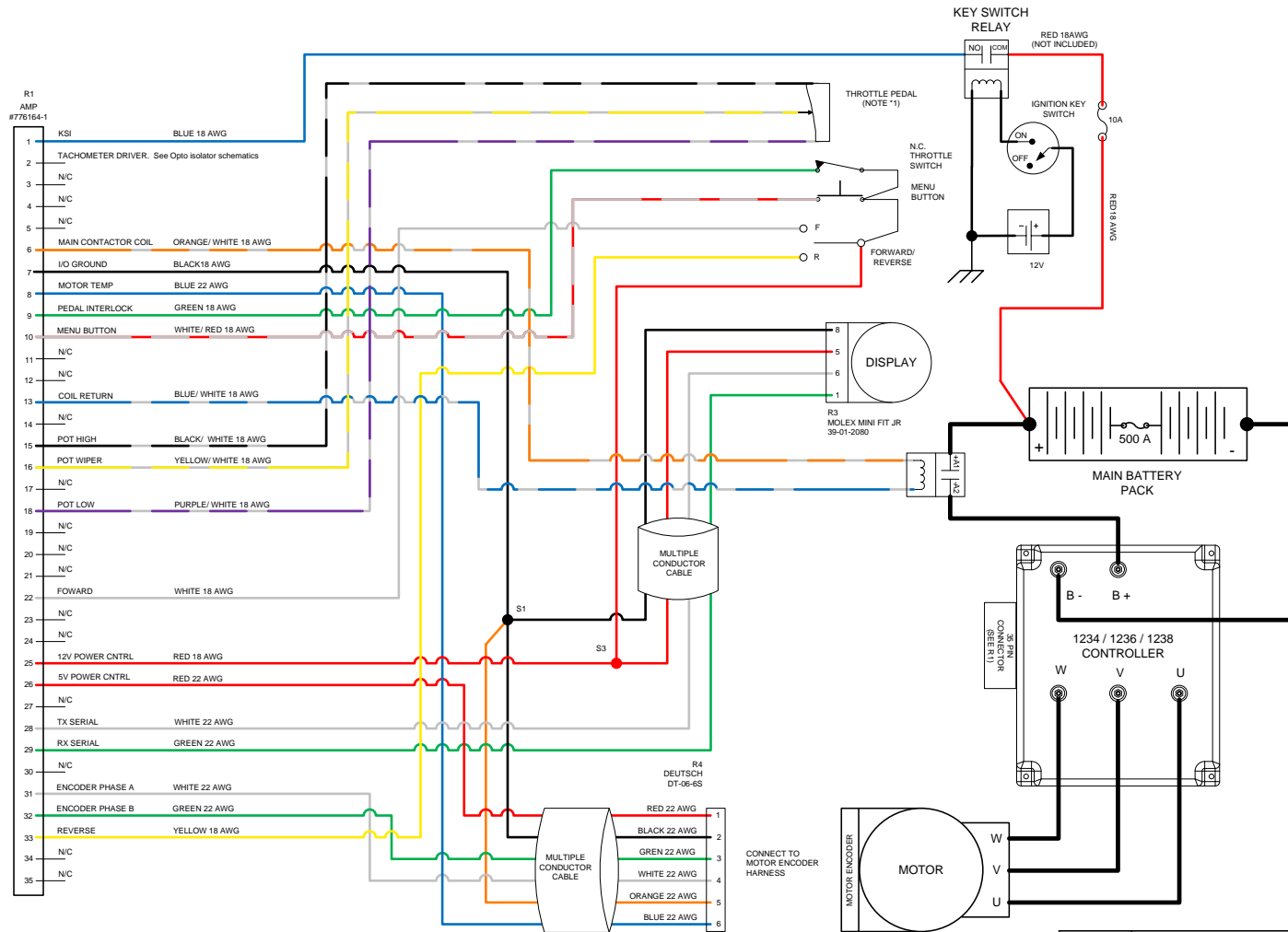

NOTES:
 (*1) DEFAULT TYPE 3 PARAMETER. BLACK AND WHITE NOT USED ON 2 WIRE THROTTLE POT
 (*2) USE SUPPLIED CONTACTOR

CAD TYPE	VISIO		
APPLICABLE SOFTWARE			
UNIT	DRAWING 1010-AUTO-CONVERSION		
DRW SIZE	TITTLE		
DATE	ON-ROAD VEHICLE CONVERSION		
SCALE	SHEET 1 OF 1	REVISION	B6 HPEVS