



**620 Magnolia Avenue
Suite B
Ontario, CA 91762
(909) 923-1973**

WIRING SCHEMATICS

CLUB CAR PRECEDENT GOLF CAR

REVISION: J

Date: 9-20-18

NOTICE: This drawing is the property of Hi Performance Electric Vehicle Systems Inc. and/or its subsidiaries and affiliates (individually and collectively "HPEVS"), and contains highly proprietary, confidential, and trade secret information of HPEVS. The recipient of this drawing agrees (a) to use the information contained herein for the purpose for which it was furnished by HPEVS (b) to return this drawing upon HPEVS request. This notice shall appear on any complete or partial reproduction of this drawing.

REVISIONS		
REV	DESCRIPTION	APPROVED
A	INITIAL RELEASE	
H	Change wire gauge from 18 to 20 AWG Move splice S3 location (Harness B) in Blue wire to Blue/Red wire. Change wire color at G2 & J2 from Blue to Red/ blue	9/17/2017

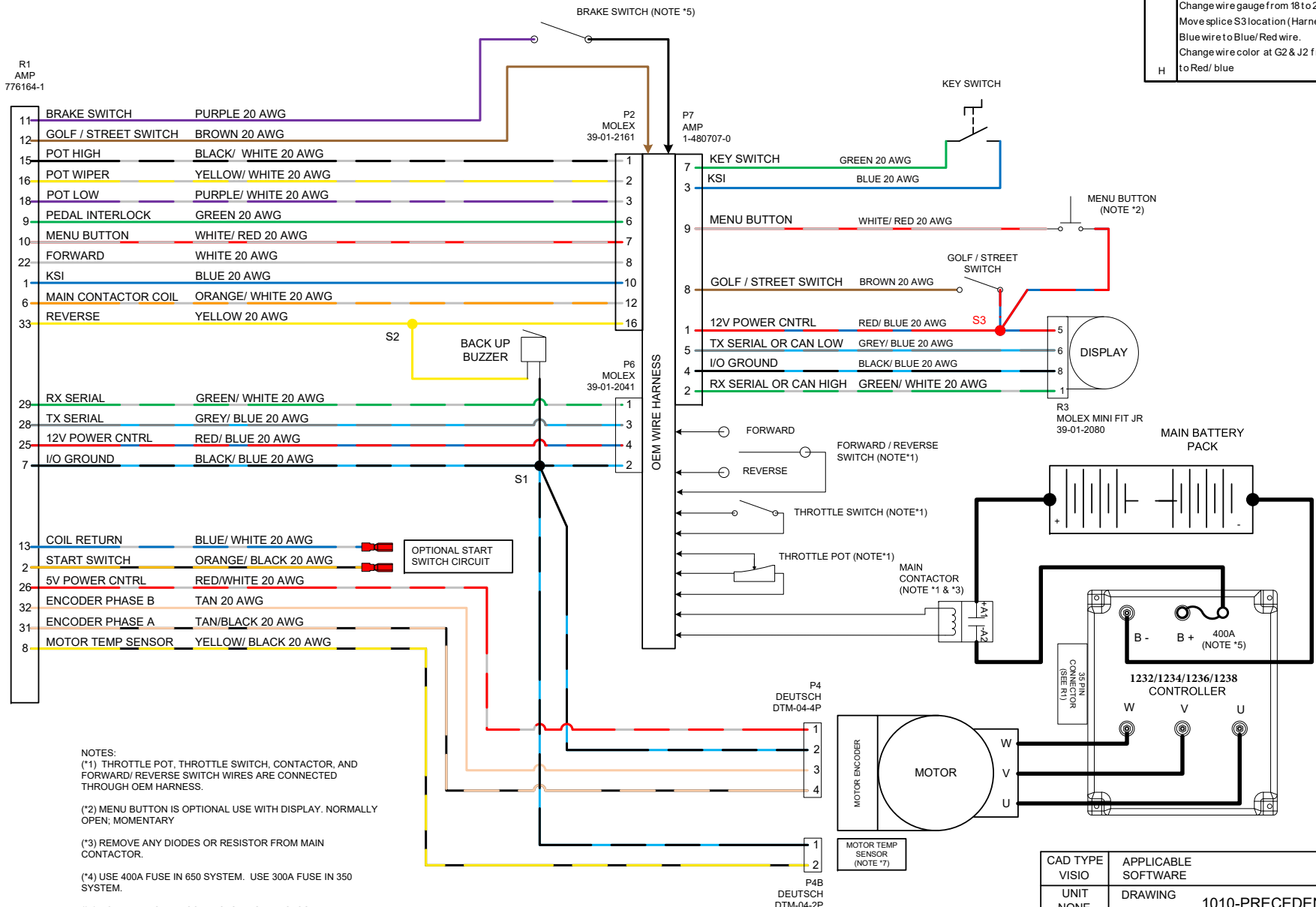

- NOTES:
- (1) THROTTLE POT, THROTTLE SWITCH, CONTACTOR, AND FORWARD/REVERSE SWITCH WIRES ARE CONNECTED THROUGH OEM HARNESS.
 - (2) MENU BUTTON IS OPTIONAL USE WITH DISPLAY. NORMALLY OPEN; MOMENTARY
 - (3) REMOVE ANY DIODES OR RESISTOR FROM MAIN CONTACTOR.
 - (4) USE 400A FUSE IN 650 SYSTEM. USE 300A FUSE IN 350 SYSTEM.
 - (5) NORMALLY OPEN. CONTACTS MUST BE CLOSED WHEN BRAKE PEDAL IS PRESSED.
 - (6) MOTOR TEMP SENSOR NOT USED FOR GOLF CART APPLICATION.

CAD TYPE	VISIO	APPLICABLE SOFTWARE
UNIT NONE	DRAWING	1010-PRECEDENT
DRW SIZE	A	TITLE
DATE	9/18/18	PRECEDENT GOLF CAR SCHEMATICS
SUPPLIER PART	HW-SET-HPG	
SCALE	none	SHEET 1 OF 1
REVISION	J	HPEVS

OPTIONAL START SWITCH BUTTON SCHEMATIC

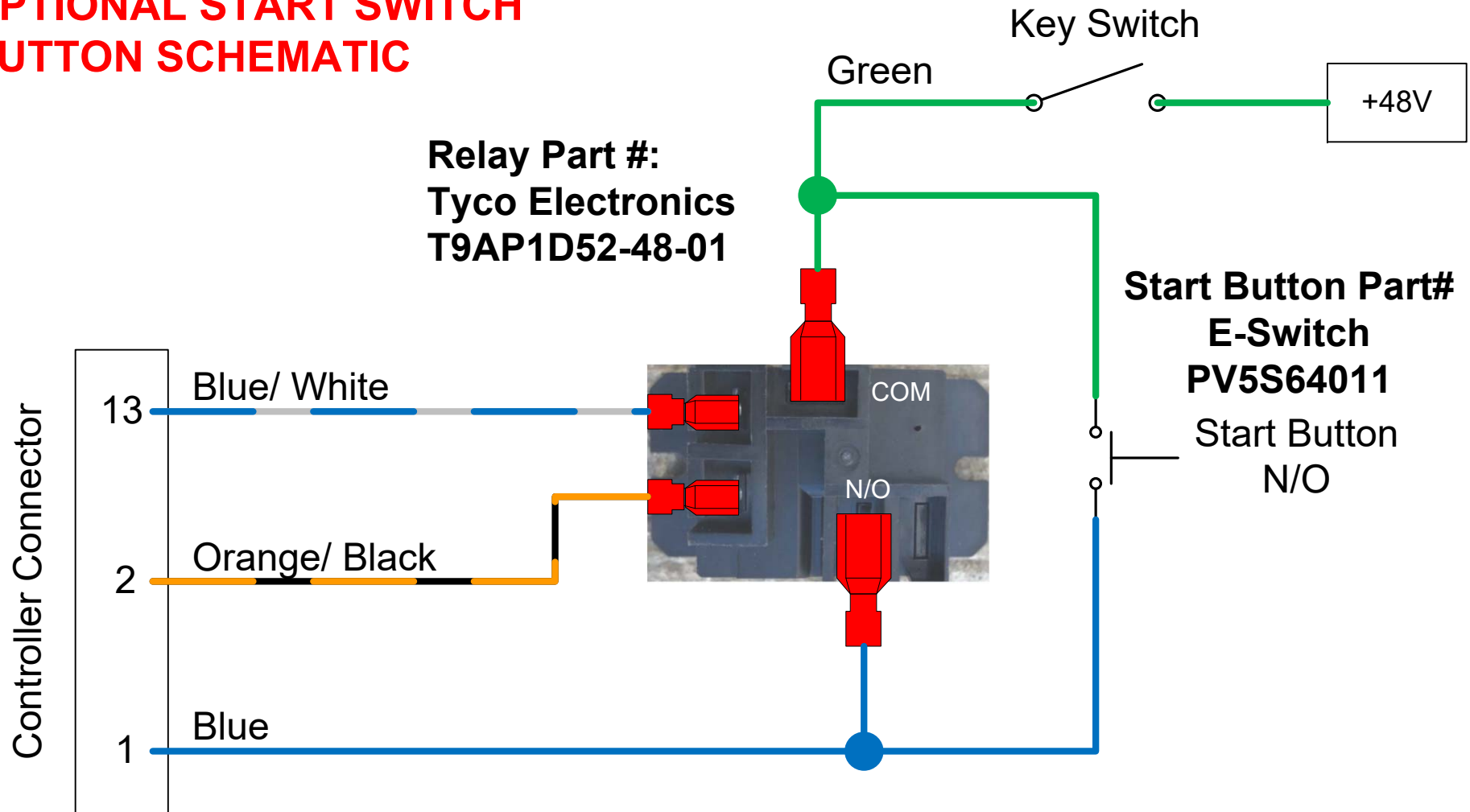

CAD TYPE	APPLICABLE SOFTWARE		
UNIT	DRAWING 1010-Start Switch		
DRW SIZE	TITLE		
DATE	Golf Cart Start Switch		
7/24/18			
SUPPLIER PART			
SCALE	SHEET 1 OF 1	REVISION 1	HPEVS
1:1			