



620 Magnolia Ave
Suite B
Ontario, CA 91762
(909) 923-1973

WIRING SCHEMATICS

ON-ROAD VEHICLE CONVERSION SINGLE AND DUAL MOTOR APPLICATION

FOR SOFTWARE VERSIONS 5.30 AND HIGHER

FOR CURTIS CONTROLLERS 1232/1234/1236/1238

REVISION: D
Date: 10/5/16

Table of Contents

Quick Start Electrical Schematics.....	3
Full Electrical Schematics 1232-1238 Controllers.....	8
Throttle Configuration.....	13
Type 1 Electronic without switch.....	14
Type 1 Curtis Electronic Throttle Model ET-126 or ET-134 without Switch...15	15
Type 2 2-Wire Pot.....	16
Type 3 3-Wire Pot.....	17
Type 3 Curtis PB-8 Throttle Assembly.....	18
Type 3 Curtis Electronic Throttle Model ET-126 or ET-134.....	19
Throttle Interlock Connection.....	20
Brake Input Configuration.....	21
Type 2 Pressure Transducer or Electronic or 3-Wire Pot.....	22
Type 3 2-Wire Pot.....	23
Brake Light Configurations.....	24
CAN-OP Isolator Modules.....	26
Program Entries (Parameters).....	28
Monitor Items.....	31
Glossary of Terms.....	32
Dual Motor Encoder Isolator.....	34

QUICK START GENERIC ELECTRICAL SCHEMATICS

1232-1238 CONTROLLERS

The following quick start electrical schematics for both single and dual motor configurations have been generated to assist in quickly getting the drive system connected and running.

NOTICE: This drawing is the property of Hi Performance Electric Vehicle Systems Inc., and/or its subsidiaries and affiliates (individually and collectively "HPEVS"), and contains highly proprietary, confidential, and trade secret information of HPEVS. The recipient of this drawing agrees (a) to use the information contained herein for the purpose for which it was furnished by HPEVS (b) to return this drawing upon HPEVS request. This notice shall appear on any complete or partial reproduction of this drawing.

REVISIONS		
REV	DESCRIPTION	APPROVED
A	Initial Release	4/18/2016

QUICK START SCHEMATIC FOR SINGLE MOTOR OR PRIMARY MOTOR IN DUAL MOTOR CONFIGURATION CURTIS 1232 / 1234 / 1236 / 1238 CONTROLLERS

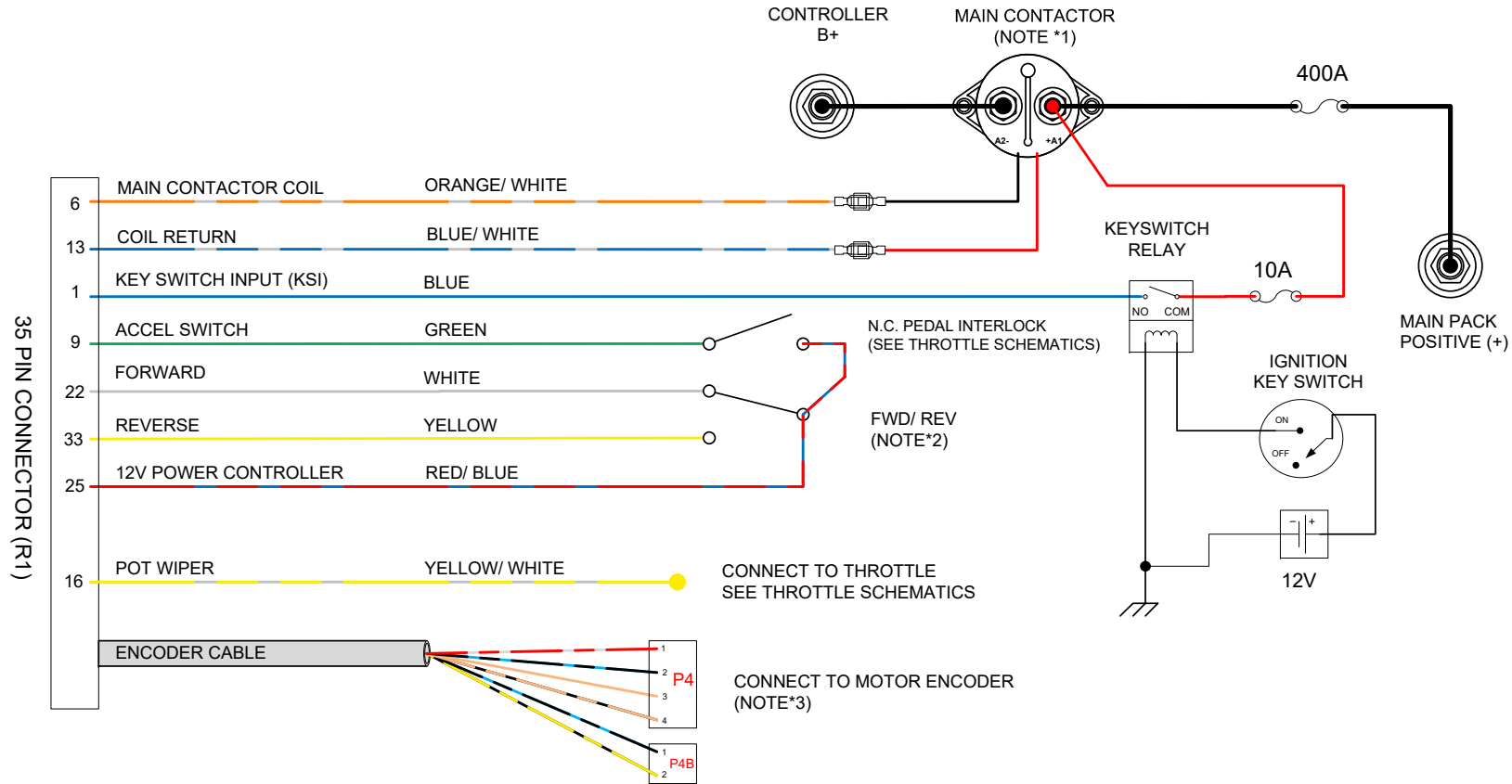

NOTES:

(*1) Use supplied contactor (GIGAVAC Part #GV200QA-1). Use only a Contactor WITHOUT PWM AND COIL SUPPRESSION. FAILURE TO DO SO CAN CAUSE CONTROLLER FAILURE AND WILL VOID WARRANTY.

(*2) Forward is CLOCKWISE motor rotation from **encoder end view**. Depending on transmission configuration, use either wire to obtain desired rotation. Use FWD & REV switch in direct drive applications.

(*3) For dual Motor applications, see dual motor encoder isolator schematics for more details.

CAD TYPE	APPLICABLE SOFTWARE	VERSION 5.30 & UP
UNIT	DRAWING 1010-AUTO-CONVERSION-QS	
DRW SIZE	TITLE QUICK START SCHEMATIC FOR 1232-1238 CONTROLLERS	
DATE	4/18/16	
SUPPLIER PART		
SCALE	SHEET 1 OF 1	REVISION B HPEVS

Quick Start Electrical Schematic Generic 530 Software Pin Out Specific for 1232-1238 Controllers Single Motor or Primary in Dual Motor Applications

Pin #	Name	Function	Terminations	Wire color	Detailed Description
1	KSI	Keyswitch_Input		Blue	Keyswitch input. Provides logic power for the controller and power for the coil drivers.
6	Driver 1	Main_Contactor		Orange/White	Main Contactor Coil Driver.
9	Switch 3	Accel_Switch_Input	Active high, connect to 12 volts. See schematic	Green	Used as safety interlock; switch is open when throttle switch is released. Type 2 & 3 throttle only.
13	Coil Return	Coil Return	Common to all relay coils	Blue/White	This is the coil return pin (at B+ potential) for all the contactor and relay coils.
16	Throttle Pot Wiper	Pot Wiper		Yellow/White	Wiper or throttle input.
22	Switch 7	Forward_Switch_Input	Active high, connect to KSI to activate.	White	Used by the Motor Control to select forward direction
25	+12V Out			Red/Blue	Unregulated low power +12V output.
33	Switch 8	Reverse_Switch_Input	Active high, connect to KSI to activate.	Yellow	Used by the Motor Control to select reverse direction

NOTICE: This drawing is the property of HiPerformance Electric Vehicle Systems Inc., and/or its subsidiaries and affiliates (individually and collectively "HPEVS"), and contains highly proprietary, confidential, and trade secret information of HPEVS. The recipient of this drawing agrees (a) to use the information contained herein for the purpose for which it was furnished by HPEVS (b) to return this drawing upon HPEVS request. This notice shall appear on any complete or partial reproduction of this drawing.

QUICK START SCHEMATIC FOR SECONDARY MOTOR CONFIGURATION CURTIS 1232 / 1234 / 1236 / 1238 CONTROLLERS

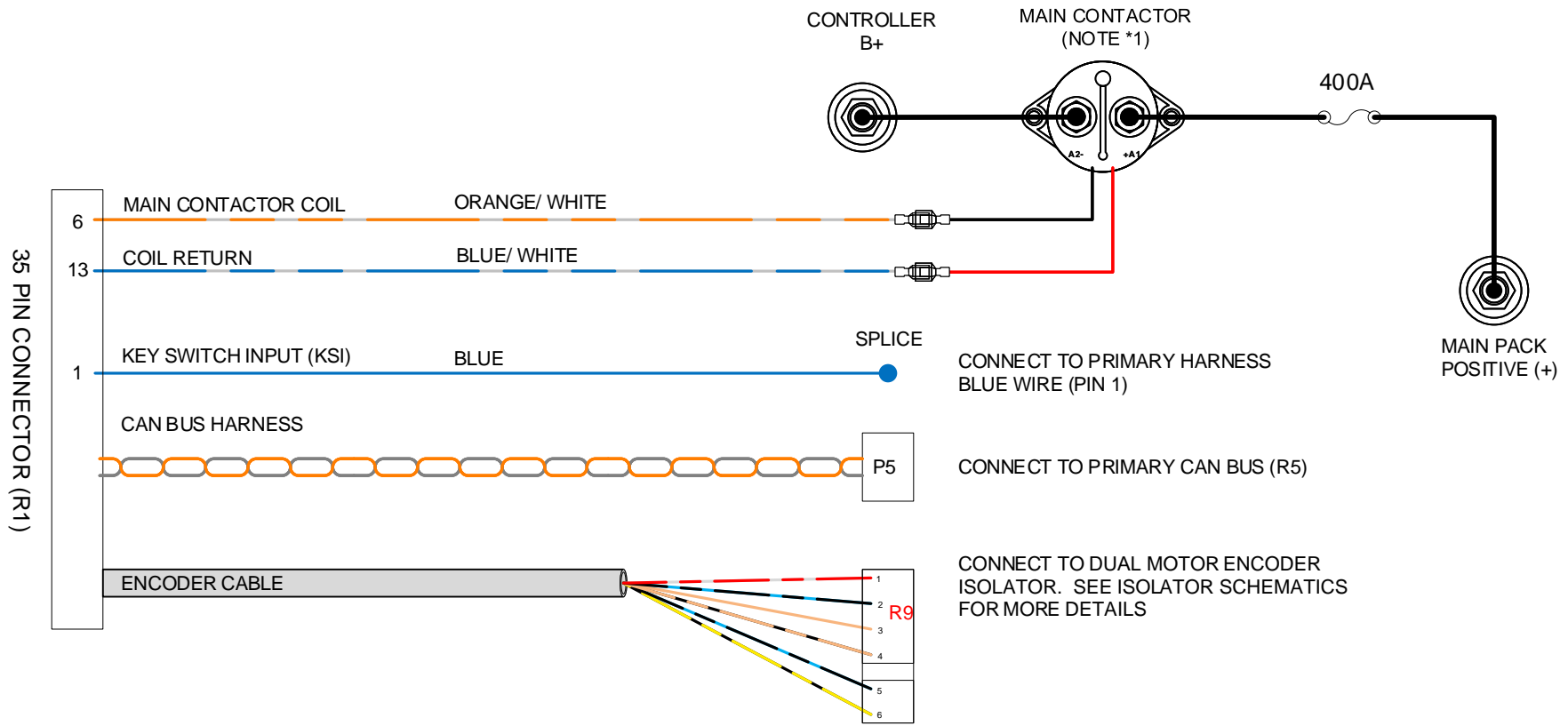

NOTES:

(*1) Use supplied contactor (GIGAVAC Part #GV200QA-1). Use only a Contactor WITHOUT PWM AND COIL SUPPRESSION. FAILURE TO DO SO CAN CAUSE CONTROLLER FAILURE AND WILL VOID WARRANTY.

CAD TYPE	APPLICABLE SOFTWARE	VERSION 5.30 & UP
UNIT	DRAWING 1010-AUTO-CONVERSION-QS-SEC	
DRW SIZE	TITLE	
DATE	QUICK START SCHEMATIC FOR SECONDARY 1232-1238 CONTROLLERS	
SUPPLIER PART		
SCALE	SHEET 1 OF 1	REVISION C HPEVS

Quick Start Electrical Schematic Generic Software Pin Out Specific for 1232-1238 Secondary Controller in Dual Motor Applications

Pin #	Name	Function	Terminations	Wire color	Detailed Description
1	KSI	Keyswitch_Input		Blue	Keyswitch input. Provides logic power for the controller and power for the coil drivers. Connect to primary harness at the Blue KSI wire.
6	Driver 1	Main_Contactor		Orange/White	Main Contactor Coil Driver.
13	Coil Return	Coil Return	Common to all relay coils	Blue/White	This is the coil return pin (at B+ potential) for all the contactor and relay coils.

FULL ELECTRICAL SCHEMATICS
CURTIS 1232-1238 CONTROLLERS

NOTICE: This drawing is the property of Hi Performance Electric Vehicle Systems Inc., and/or its subsidiaries and affiliates (individually and collectively "HPEVS"), and contains highly proprietary, confidential, and trade secret information of HPEVS. The recipient of this drawing agrees (a) to use the information contained herein for the purpose for which it was furnished by HPEVS (b) to return this drawing upon HPEVS request. This notice shall appear on any complete or partial reproduction of this drawing.

ELECTRICAL SCHEMATICS FOR SINGLE MOTOR OR PRIMARY MOTOR IN DUAL MOTOR CONFIGURATION 1232 / 1234 / 1236 / 1238 CONTROLLERS

REVISIONS		
REV	DESCRIPTION	APPROVED
A	Initial Release	4/11/2016

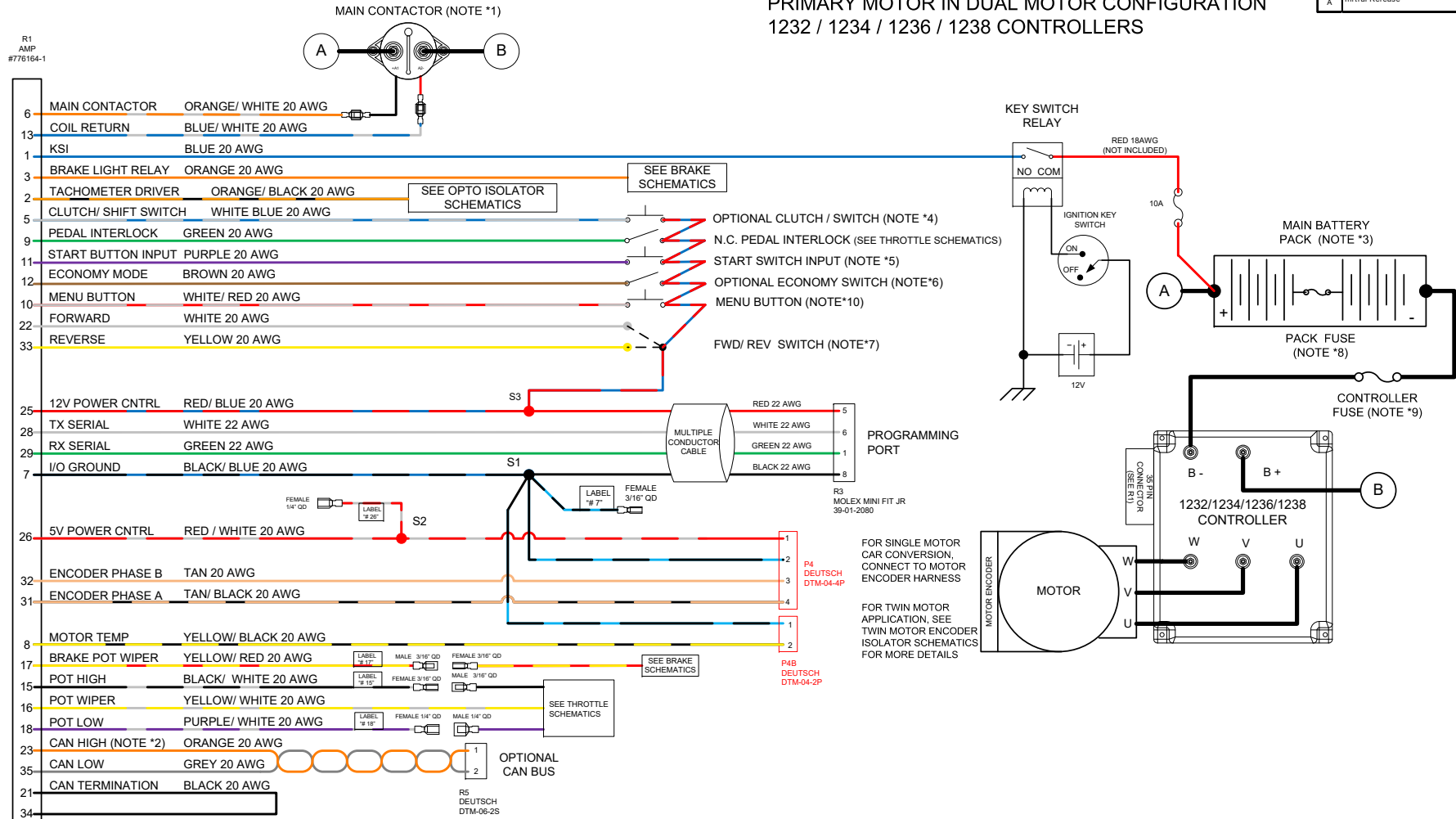

CAD TYPE VISIO	APPLICABLE SOFTWARE	Version 5.30 & up	
UNIT NONE	DRAWING	1010-AUTO-CONVERSION	
DRW SIZE A	TITLE	ON-ROAD VEHICLE CONVERSION / PRIMARY DUAL MOTOR SCHEMATICS	
DATE 4/11/16	SUPPLIER PART	HW-AUTOCONVERSION-HPG	
SCALE NONE	SHEET 1 OF 1	REVISION E	HPEVS

Generic Software 530 Switch Pin Out Specific for for 1232-1238 Single Motor or Primary in Dual Motor Applications

Pin #	Name	Function	Terminations	Wire color	Detailed Description
1	KSI	Keyswitch_Input		Blue	Keyswitch input. Provides logic power for the controller and power for the coil drivers.
2	Prop. Driver	Tachometer Driver		Orange/Black	Digital output used to drive a tachometer
3	Driver 4	Brake Light Relay		Orange	Brake light relay driver
4	N/C				
5	Switch 10	Clutch/Shift Switch		White/Blue	Switch input is used to reduce neutral braking while shifting
6	Driver 1	Main_Contactor		Orange/White	Main Contactor Coil Driver.
7	I/O Ground			Black/Blue	Input and output ground reference.
8	Analog 2	Motor_Temperature_Sensor		Yellow/Black	Used as the motor temperature analog input
9	Switch 3	Accel_Switch_Input	Active high, connect to 12 volts. See schematic	Green	Used as safety interlock; switch is open when throttle switch is released. Type 2 & 3 throttle only.
10	Menu	Menu_Button	Active high, connect to 12 volts. See schematic	White/Red	Momentary switch; used to scroll through 840 spyglass display
11	Switch 5	Start_Switch_Input	Active high, connect to 12 volts. See schematic	Purple	Momentary switch; Enables drive system when Idle function is turned ON.
12	Switch 6	Economy_Mode_Switch_Input	Active high, connect to 12 volts. See schematic	Brown	Switch input used to activate Economy Mode.
13	Coil Return	Coil Return	Common to all relay coils	Blue/White	This is the coil return pin (at B+ potential) for all the contactor and relay coils.
14	N/C				
15	Throttle Pot High	Pot High		Black/White	Pot high connection for a 3-wire throttle pot.
16	Throttle Pot Wiper	Pot Wiper		Yellow/White	Wiper or throttle input.
17	Pot2 Wiper	Brake Pot Wiper		Yellow/Red	Brake input.
18	Pot Low	Pot Low		Purple/White	Pot low connection for brake and throttle.
19	N/C				
20	N/C				
21	CAN Term H	CAN Termination		Black	CAN termination jumper.
22	Switch 7	Forward_Switch_Input	Active high, connect to 12 volts. See schematic	White	Used by the Motor Control to select forward direction
23	CANH	CAN High		Orange	CAN bus high.
24	N/C				
25	+12V Out			Red/Blue	Unregulated low power +12V output.
26	+5V Out			Red/White	Regulated low power +5V output.
27	N/C				
28	Serial TX			White	Serial transmit line for display or flash update.
29	Serial RX			Green	Serial receive line for display or flash update.
30	N/C				
31	Encoder Phase A	MotorspeedA_Input		Tan/Black	Quadrature encoder input phase A
32	Encoder Phase B	MotorspeedB_Input		Tan	Quadrature encoder input phase B
33	Switch 8	Reverse_Switch_Input	Active high, connect to 12 volts. See schematic	Yellow	Used by the Motor Control to select reverse direction
34	CAN Term L	CAN Termination		Black	CAN bus termination jumper.
35	CANL	CAN Low		Grey	CAN bus low.

NOTICE: This drawing is the property of HI Performance Electric Vehicle Systems Inc., and/or its subsidiaries and affiliates (individually and collectively "HPEVS"), and contains highly proprietary, confidential, and trade secret information of HPEVS. The recipient of this drawing agrees (a) to use the information contained herein for the purpose for which it was furnished by HPEVS (b) to return this drawing upon HPEVS request. This notice shall appear on any complete or partial reproduction of this drawing.

DUAL MOTOR 1232 / 1234 / 1236 / 1238 CONTROLLERS SECONDARY MOTOR ELECTRICAL SCHEMATICS

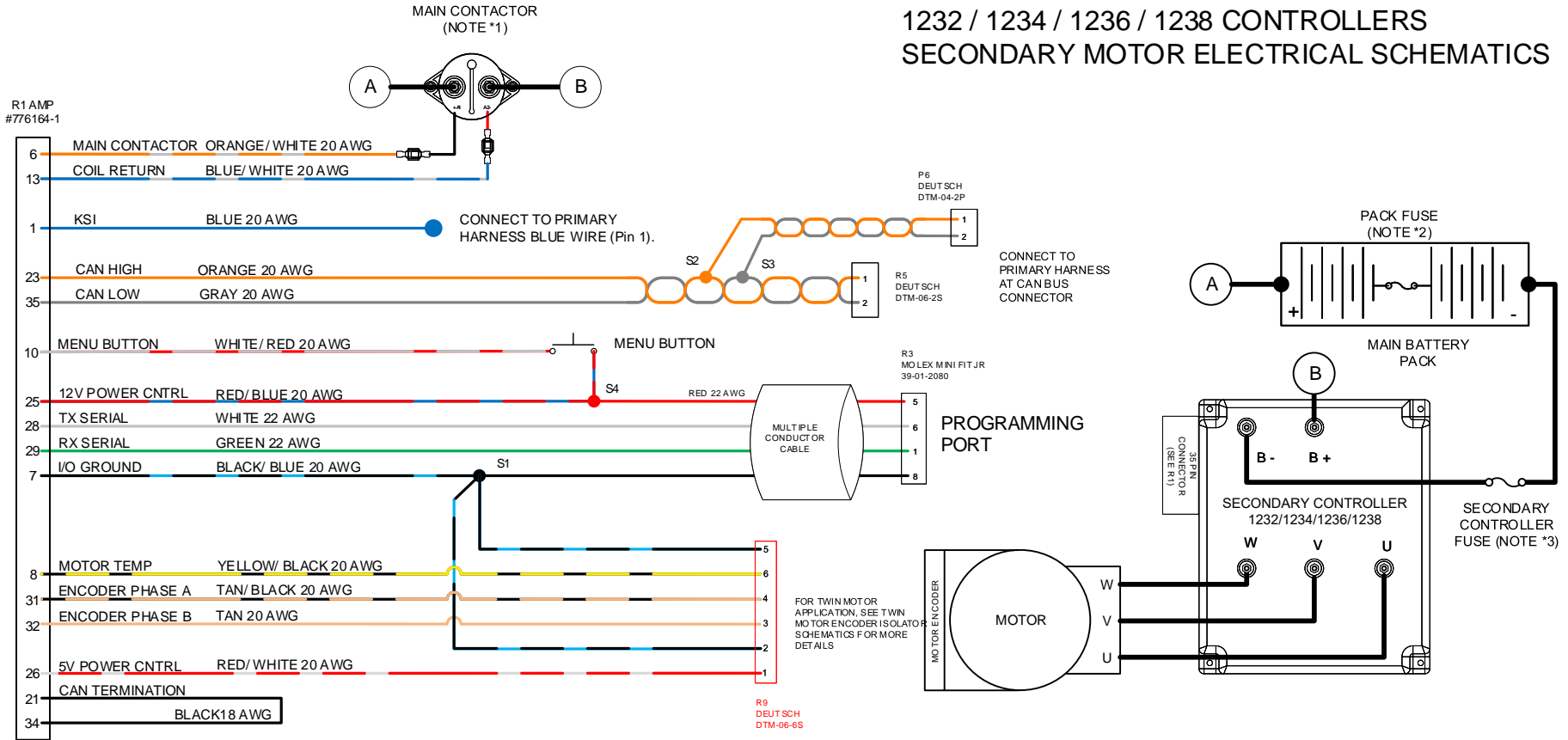

NOTES:

(*1) **USE SUPPLIED CONTACTOR**

(*2) Use Pack Fuse rated at 500A for Single controller applications. For Dual controller use 800A Pack fuse.

(*3) Only for Dual motor application. Use Controller Fuse rated at 500A for each controller.

CAD TYPE VISIO	APPLICABLE SOFTWARE Version 5.30 & up
UNIT NONE	DRAWING 1010-AUTO-CONVERSION-SEC
DRW SIZE A	TITLE 1232-1238 CONTROLLER SECONDARY MOTOR SCHEMATICS
DATE 3/28/19	
SUPPLIER PART	HW-1010AUTO-HPG
SCALE none	SHEET 1 OF 1
REVISION D	HPEVS

Generic Software 530 Switch Pin Out Specific for for 1232-1238 Secondary Controller in Dual Motor Applications

Pin #	Name	Function	Terminations	Wire color	Detailed Description
1	KSI	Keyswitch_Input		Blue	Keyswitch input. Provides logic power for the controller and power for the coil drivers. Connect to primary harness at the Blue KSI wire.
2	N/C				
3	N/C				
4	N/C				
5	N/C				
6	Driver 1	Main_Contactor		Orange/White	Main Contactor Coil Driver.
7	I/O Ground			Black/Blue	Input and output ground reference.
8	Analog 2	Motor_Temperature_Sensor		Yellow/Black	Used as the motor temperature analog input
9	N/C				
10	Menu	Menu_Button	Active high, connect to 12 volts. See schematic	White/Red	Momentary switch; used to scroll through 840 spyglass display
11	N/C				
12	N/C				
13	Coil Return	Coil Return	Common to all relay coils	Blue/White	This is the coil return pin (at B+ potential) for all the contactor and relay coils.
14	N/C				
15	N/C				
16	N/C				
17	N/C				
18	N/C				
19	N/C				
20	N/C				
21	CAN Term H	CAN Termination		Black	CAN termination jumper.
22	N/C				
23	CANH	CAN High		Orange	CAN bus high.
24	N/C				
25	+12V Out			Red/Blue	Unregulated low power +12V output.
26	+5V Out			Red/White	Regulated low power +5V output.
27	N/C				
28	Serial TX			White	Serial transmit line for display or flash update.
29	Serial RX			Green	Serial receive line for display or flash update.
30	N/C				
31	Encoder Phase A	MotorspeedA_Input		Tan/Black	Quadrature encoder input phase A
32	Encoder Phase B	MotorspeedB_Input		Tan	Quadrature encoder input phase B
33	N/C				
34	CAN Term L	CAN Termination		Black	CAN bus termination jumper.
35	CANL	CAN Low		Grey	CAN bus low.

THROTTLE CONFIGURATION

Depending on the type of throttle used for the application, the different types of throttle configurations are listed within the table below. Electrical schematics are also included within the following pages.

THROTTLE CONFIGURATION	TYPE
ELECTRONIC without SWITCH CURTIS ET-126/ET-134 ELECTRONIC THROTTLE ASSEMBLY without SWITCH	TYPE 1
2 WIRE with SWITCH 0-5k Ω	TYPE 2
3 WIRE with SWITCH 0-5k Ω	TYPE 3 Default
CURTIS PB8 THROTTLE ASSEMBLY	TYPE 3
CURTIS ET-126/ET-134 ELECTRONIC THROTTLE ASSEMBLY WITH SWITCH	TYPE 3

NOTICE: This drawing is the property of Hi Performance Electric Vehicle Systems Inc., and/or its subsidiaries and affiliates (individually and collectively "HPEVS"), and contains highly proprietary, confidential, and trade secret information of HPEVS. The recipient of this drawing agrees (a) to use the information contained herein for the purpose for which it was furnished by HPEVS (b) to return this drawing upon HPEVS request. This notice shall appear on any complete or partial reproduction of this drawing.

REVISIONS		
REV	DESCRIPTION	APPROVED
A	INITIAL RELEASE	1/22/2013

TYPE 1 ELECTRONIC THROTTLE

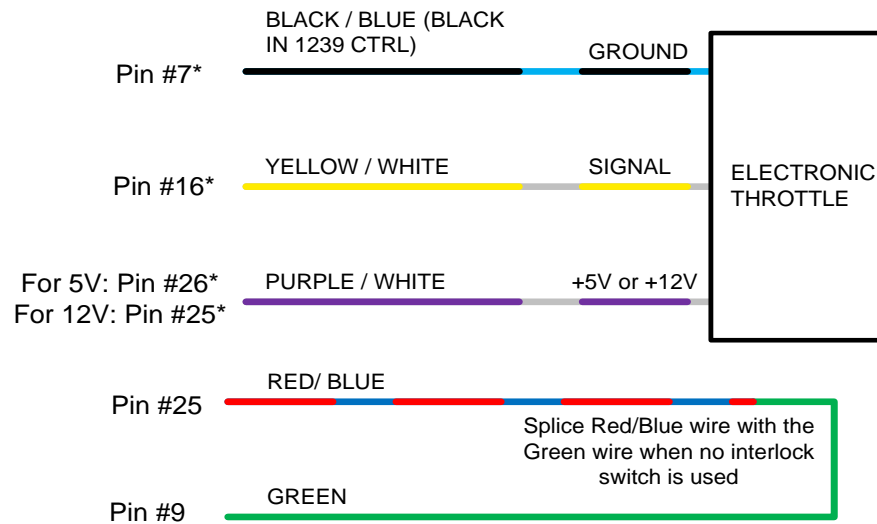

* Typical connection, verify correct voltage and connection in throttle documents or instructions.

Not all Electronic Throttles supported

CAD TYPE VISIO	APPLICABLE SOFTWARE		
UNIT NONE	DRAWING 1010-THROTTLE-001		
DRW SIZE A	TITLE ELECTRONIC THROTTLE		
DATE 1/22/13			
SUPPLIER PART			
SCALE NONE	SHEET 1 OF 1	REVISION A	HPEVS

NOTICE: This drawing is the property of Hi Performance Electric Vehicle Systems, Inc., and/or its subsidiaries and affiliates (individually and collectively "HPEVS"), and contains highly proprietary, confidential, and trade secret information of HPEVS. The recipient of this drawing agrees: (a) to use the information contained herein for the purpose for which it was furnished by HPEVS (b) to return this drawing upon HPEVS request. This notice shall appear on any complete or partial reproduction of this drawing.

REVISIONS		
REV	DESCRIPTION	APPROVED
A	Initial Release	11/17/2015

CURTIS ELECTRONIC THROTTLE MODEL NUMBERS ET-126 OR ET-134 TYPE 1 WITHOUT SWITCH

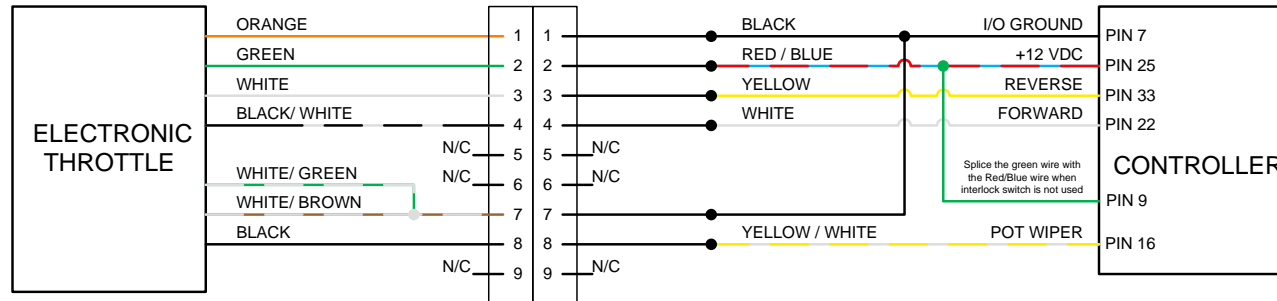

ET-126 HAS A SPRING RETURN SO THAT THE THROTTLE RETURNS TO NEUTRAL POSITION

ET-134 DOES NOT HAVE A SPRING RETURN

CAD TYPE	APPLICABLE SOFTWARE	VER 2.5
UNIT NONE	DRAWING 1010-ETHrottle	
DRW SIZE A	TITLE Curtis Electronic Throttle Part ET-126 OR ET-134 Type 1	
DATE 11/17/15		
SUPPLIER PART		
SCALE none	SHEET 1 OF 1	REVISION A HPEVS

NOTICE: This drawing is the property of Hi Performance Electric Vehicle Systems Inc., and/or its subsidiaries and affiliates (individually and collectively "HPEVS"), and contains highly proprietary, confidential, and trade secret information of HPEVS. The recipient of this drawing agrees (a) to use the information contained herein for the purpose for which it was furnished by HPEVS (b) to return this drawing upon HPEVS request. This notice shall appear on any complete or partial reproduction of this drawing.

REVISIONS		
REV	DESCRIPTION	APPROVED
A	INITIAL RELEASE	1/22/2013
B	REVISION	1/27/2013

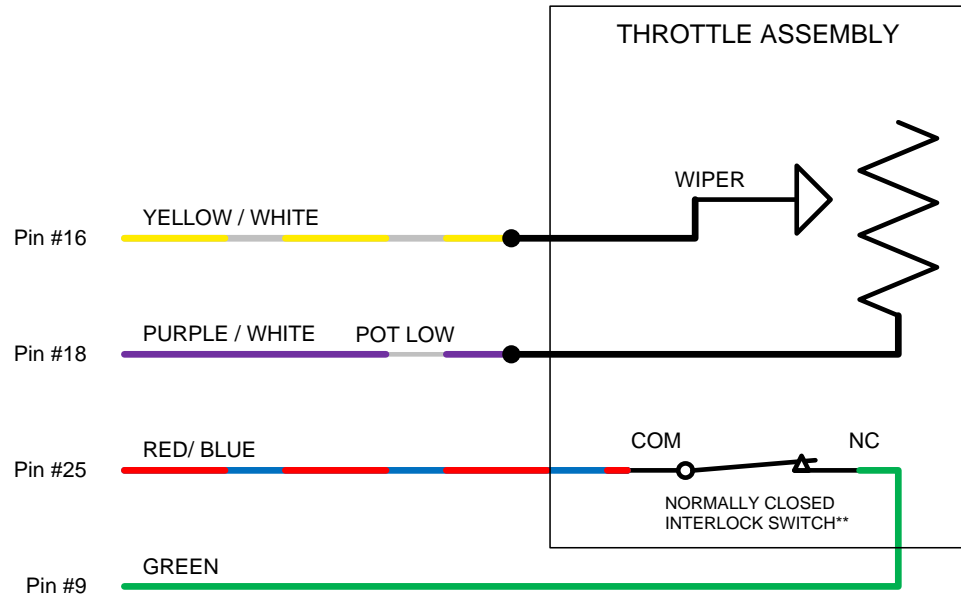

TYPE 2 2 WIRE THROTTLE

** When accelerator pedal IS PRESSED the interlock switch is released to its NORMAL position (switch not activated) thus completing the circuit since its green wire is connected to the normally closed (NC) connection.

CAD TYPE VISIO	APPLICABLE SOFTWARE
UNIT NONE	DRAWING 1010-THROTTLE-001
DRW SIZE A	TITLE
DATE 1/22/13	TYPE 2 2 WIRE THROTTLE
SUPPLIER PART	
SCALE NONE	SHEET 1 OF 8
REVISION	B
HPEVS	

NOTICE: This drawing is the property of Hi Performance Electric Vehicle Systems Inc., and/or its subsidiaries and affiliates (individually and collectively "HPEVS"), and contains highly proprietary, confidential, and trade secret information of HPEVS. The recipient of this drawing agrees (a) to use the information contained herein for the purpose for which it was furnished by HPEVS (b) to return this drawing upon HPEVS request. This notice shall appear on any complete or partial reproduction of this drawing.

REVISIONS		
REV	DESCRIPTION	APPROVED
A	INITIAL RELEASE	1/22/2013
B	REVISION	1/27/2013

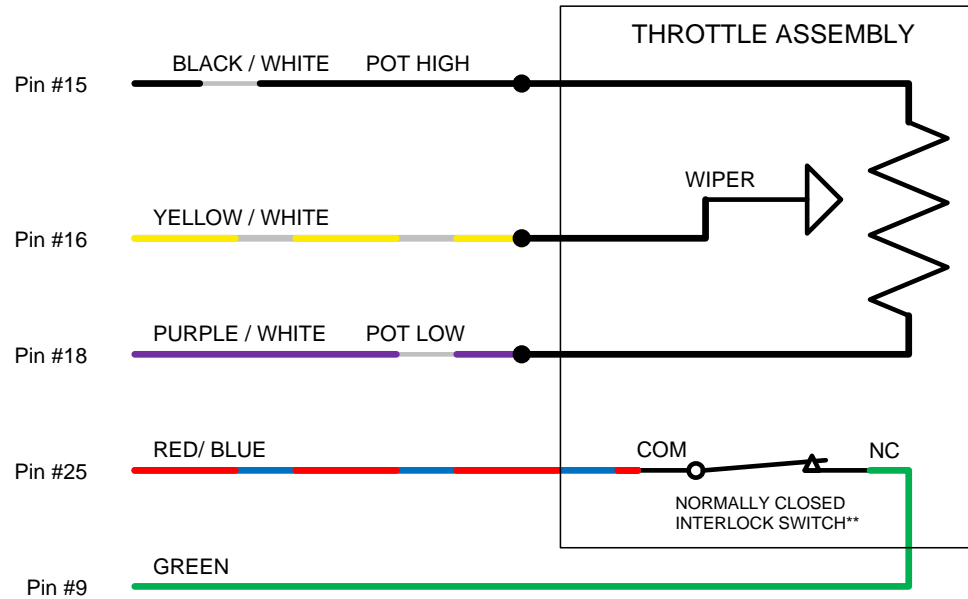

TYPE 3 3 WIRE THROTTLE

** When accelerator pedal IS PRESSED the interlock switch is released to its NORMAL position (switch not activated) thus completing the circuit since its green wire is connected to the normally closed (NC) connection.

CAD TYPE VISIO	APPLICABLE SOFTWARE
UNIT NONE	DRAWING 1010-THROTTLE-001
DRW SIZE A	TITLE TYPE 3 3 WIRE THROTTLE
DATE 1/22/13	
SUPPLIER PART	
SCALE NONE	SHEET 2 OF 8
REVISION	B
HPEVS	

NOTICE: This drawing is the property of Hi Performance Electric Vehicle Systems Inc., and/or its subsidiaries and affiliates (individually and collectively "HPEVS"), and contains highly proprietary, confidential, and trade secret information of HPEVS. The recipient of this drawing agrees (a) to use the information contained herein for the purpose for which it was furnished by HPEVS (b) to return this drawing upon HPEVS request. This notice shall appear on any complete or partial reproduction of this drawing.

REVISIONS		
REV	DESCRIPTION	APPROVED
A	INITIAL RELEASE	1/27/2013

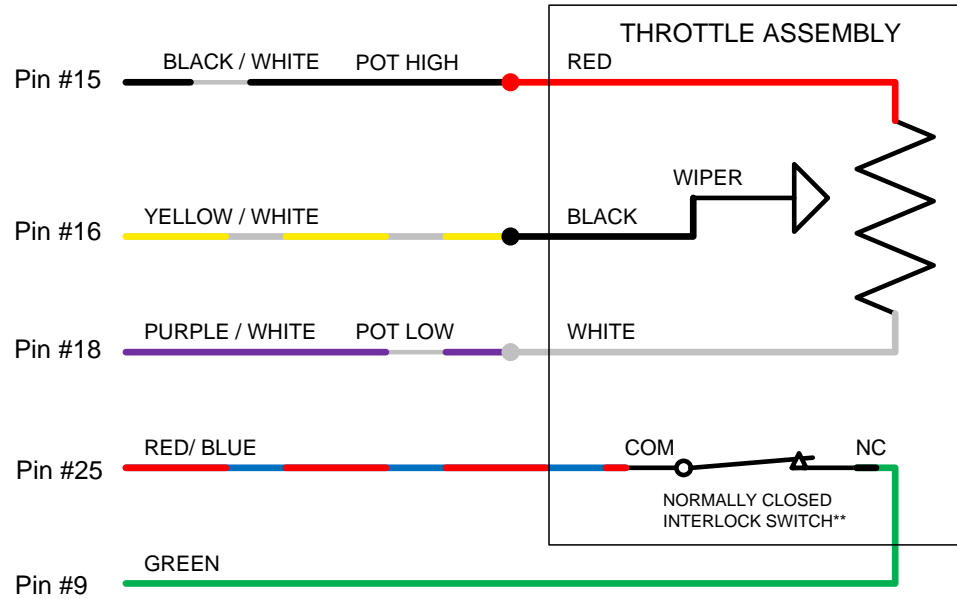

CURTIS PB8 THROTTLE ASSEMBLY

** When the accelerator pedal IS PRESSED the interlock switch is released to its NORMAL position (switch not activated) thus completing the circuit since its green wire is connected to the normally closed (NC) connection.

CAD TYPE VISO	APPLICABLE SOFTWARE		
UNIT NONE	DRAWING 1010-THROTTLE-001		
DRW SIZE A	TITLE CURTIS PB8 THROTTLE ASSEMBLY		
DATE 1/22/13			
SUPPLIER PART			
SCALE NONE	SHEET 3 OF 4	REVISION A	HPEVS

NOTICE: This drawing is the property of Hi Performance Electric Vehicle Systems, Inc., and/or its subsidiaries and affiliates (individually and collectively "HPEVS"), and contains highly proprietary, confidential, and trade secret information of HPEVS. The recipient of this drawing agrees: (a) to use the information contained herein for the purpose for which it was furnished by HPEVS (b) to return this drawing upon HPEVS request. This notice shall appear on any complete or partial reproduction of this drawing.

REVISIONS		
REV	DESCRIPTION	APPROVED
A	Initial Release	11/17/2015

CURTIS ELECTRONIC THROTTLE MODEL NUMBERS ET-126 OR ET-134 TYPE 3

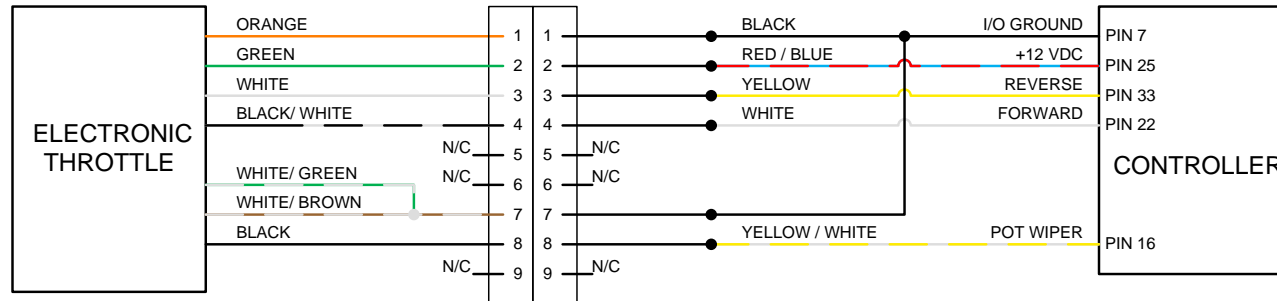

ET-126 HAS A SPRING RETURN SO THAT THE THROTTLE RETURNS TO NEUTRAL POSITION

ET-134 DOES NOT HAVE A SPRING RETURN

CAD TYPE	APPLICABLE SOFTWARE	VER 2.5
UNIT NONE	DRAWING 1010-ETHrottle	
DRW SIZE A	TITLE Curtis Electronic Throttle Part ET-126 OR ET-134 Type 3	
DATE 11/17/15		
SUPPLIER PART		
SCALE none	SHEET 1 OF 1	REVISION A HPEVS

THROTTLE INTERLOCK CONNECTION

The pedal interlock connection is required for both 2 and 3 wire throttle pot assemblies. The Green wire is connected to the Normally Closed tab. The red/blue wire is connected to the common tab. See picture below.

NOTE: when the accelerator pedal IS PRESSED the interlock switch is released to its NORMAL position (switch not activated) thus completing the circuit since its green wire is connected to the normally closed (NC) connection.

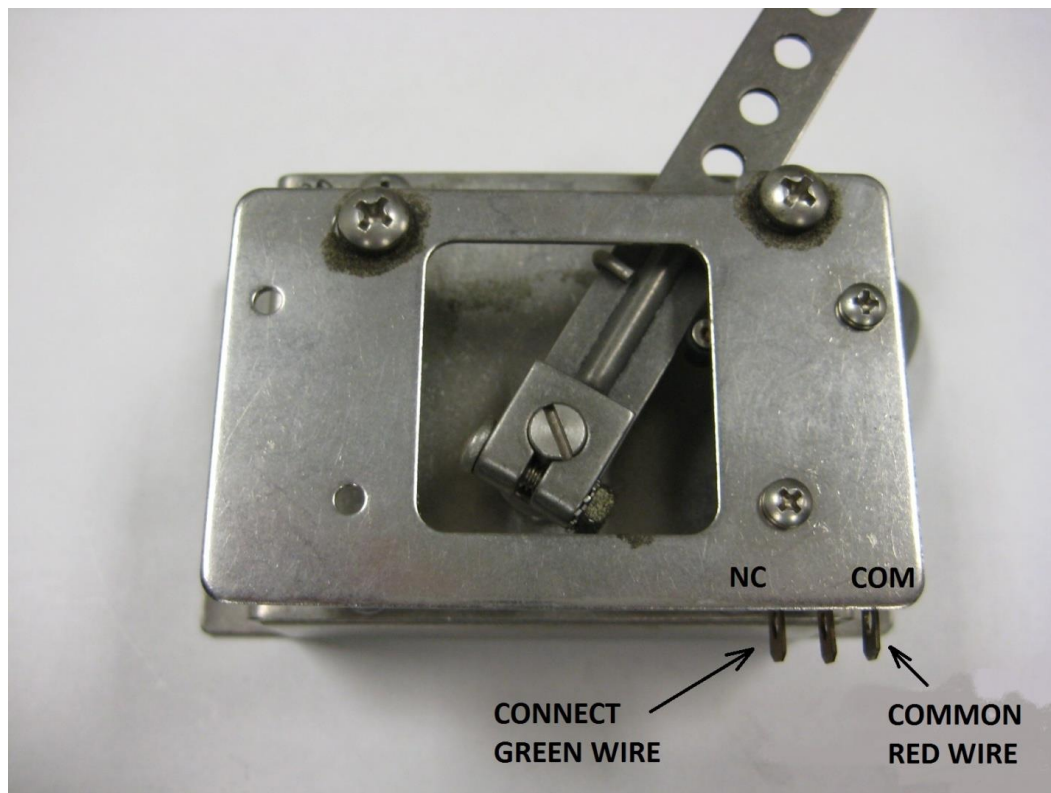

BRAKE INPUT CONFIGURATION

Depending on the type of brake input used for the application, the different types of brake input configurations are listed within the table below. Electrical schematics are also included in the following pages.

BRAKE INPUT CONFIGURATION	TYPE
PRESSURE TRANSDUCER/ ELECTRONIC 0-5V INPUT or 3-WIRE POT	TYPE 2
2 WIRE 0-5k Ω POT	TYPE 3
SWITCH	TYPE 5

NOTICE: This drawing is the property of Hi Performance Electric Vehicle Systems Inc., and/or its subsidiaries and affiliates (individually and collectively "HPEVS"), and contains highly proprietary, confidential, and trade secret information of HPEVS. The recipient of this drawing agrees (a) to use the information contained herein for the purpose for which it was furnished by HPEVS (b) to return this drawing upon HPEVS request. This notice shall appear on any complete or partial reproduction of this drawing.

REVISIONS		
REV	DESCRIPTION	APPROVED
A	INITIAL RELEASE	2/19/2013

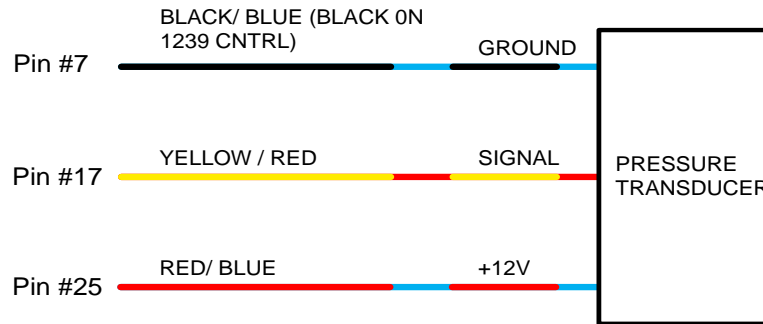

TYPE 2 PRESSURE TRANSDUCER



** Typical Pressure Transducer Ratings
 8-30 Volt Input
 1-5 Volt Output
 2500 PSI

Website Link: www.digikey.com
Part Number: M3041-000005-2K5PG-ND
Manufacturer Part #: M3041-000005-2K5PG

CAD TYPE VISIO	CAD LOC.	CAD FILE	DRW SIZE A
OPER. NO.	UNIT	DRAWING 1010-BRAKE	
DESIGN	DETAIL	TITLE	
CHECKED	SAFETY	PRESSURE TRANSDUCER	
SCALE NONE	DATE 2/19/13	REVISION A	HPEVS
		SHEET 2 OF 2	

NOTICE: This drawing is the property of Hi Performance Electric Vehicle Systems Inc., and/or its subsidiaries and affiliates (individually and collectively "HPEVS"), and contains highly proprietary, confidential, and trade secret information of HPEVS. The recipient of this drawing agrees (a) to use the information contained herein for the purpose for which it was furnished by HPEVS (b) to return this drawing upon HPEVS request. This notice shall appear on any complete or partial reproduction of this drawing.

REVISIONS		
REV	DESCRIPTION	APPROVED
A	INITIAL RELEASE	2/19/2013

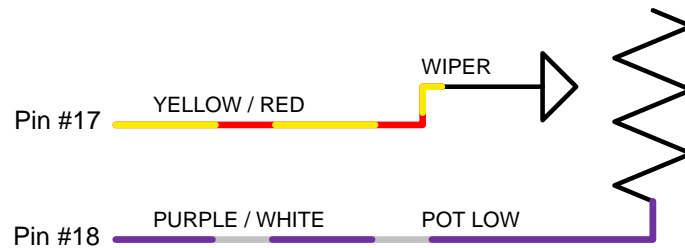

**TYPE 3
2 WIRE BRAKE POT**

CAD TYPE VISIO	CAD LOC.	CAD FILE	DRW SIZE A
OPER. NO.	UNIT	DRAWING 1010-BRAKE	
DESIGN	DETAIL	TITLE	
CHECKED	SAFETY	2 WIRE BRAKE POT	
SCALE NONE	DATE 2/19/13	REVISION A	HPEVS
		SHEET 1 OF 1	

OPTIONAL ACTIVE BRAKE LIGHT CONFIGURATIONS

These optional active brake light configurations are used to activate the brake lights during regenerative braking or when the vehicle brakes are being applied. Based on the brake type configuration that is being used in the application use one of the following wiring configurations.

NOTICE: This drawing is the property of Hi Performance Electric Vehicle Systems Inc., and/or its subsidiaries and affiliates (individually and collectively "HPEVS"), and contains highly proprietary, confidential, and trade secret information of HPEVS. The recipient of this drawing agrees (a) to use the information contained herein for the purpose for which it was furnished by HPEVS (b) to return this drawing upon HPEVS request. This notice shall appear on any complete or partial reproduction of this drawing.

REVISIONS		
REV	DESCRIPTION	APPROVED
A	INITIAL RELEASE	2/19/2013

**OPTION 1
FOR BRAKE TYPE 2, 3 OR 5 CONFIGURATIONS
1232/1234/1236/1238 CONTROLLERS**

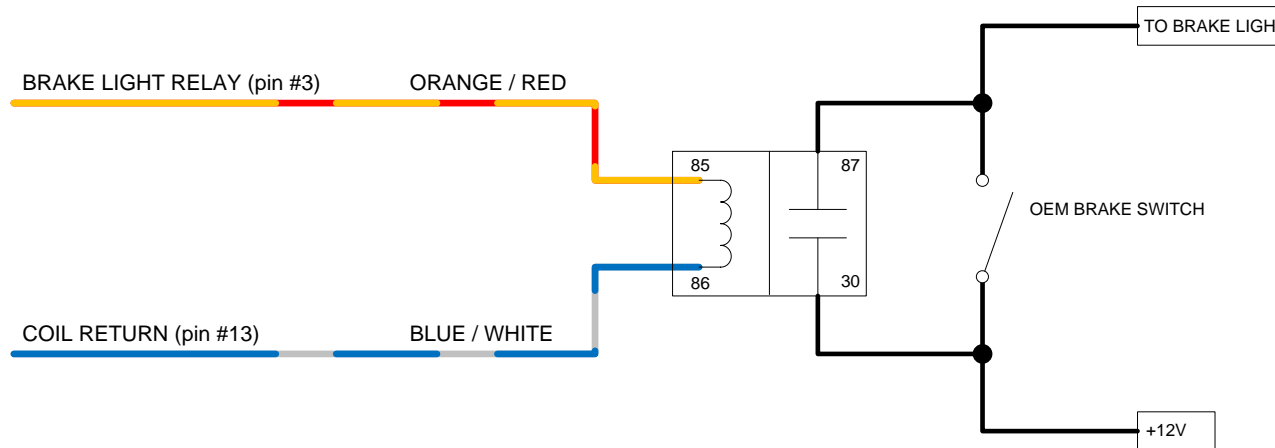

** This option turns the brake lights ON during REGEN. Brake TYPE 5 allows for NEUTRAL BRAKING AND/OR BOOSTED REGEN while pressing the brake pedal. Brake TYPE 2 & 3 uses a variable input for BOOSTED REGEN.

CAD TYPE VISIO	CAD LOC.	CAD FILE	DRW SIZE A
OPER. NO.	UNIT	DRAWING 1010-BRAKE	
DESIGN	DETAIL	TITLE	
CHECKED	SAFETY	OPTION 1 BRAKE LIGHT SWITCH	
SCALE NONE	DATE 12/5/13	REVISION A SHEET 3 OF 4	HPEVS

NOTICE: This drawing is the property of Hi Performance Electric Vehicle Systems Inc., and/or its subsidiaries and affiliates (individually and collectively "HPEVS"), and contains highly proprietary, confidential, and trade secret information of HPEVS. The recipient of this drawing agrees (a) to use the information contained herein for the purpose for which it was furnished by HPEVS (b) to return this drawing upon HPEVS request. This notice shall appear on any complete or partial reproduction of this drawing.

REVISIONS		
REV	DESCRIPTION	APPROVED
A	INITIAL RELEASE	3/11/2013
B	Revision for clarification	10/30/2013

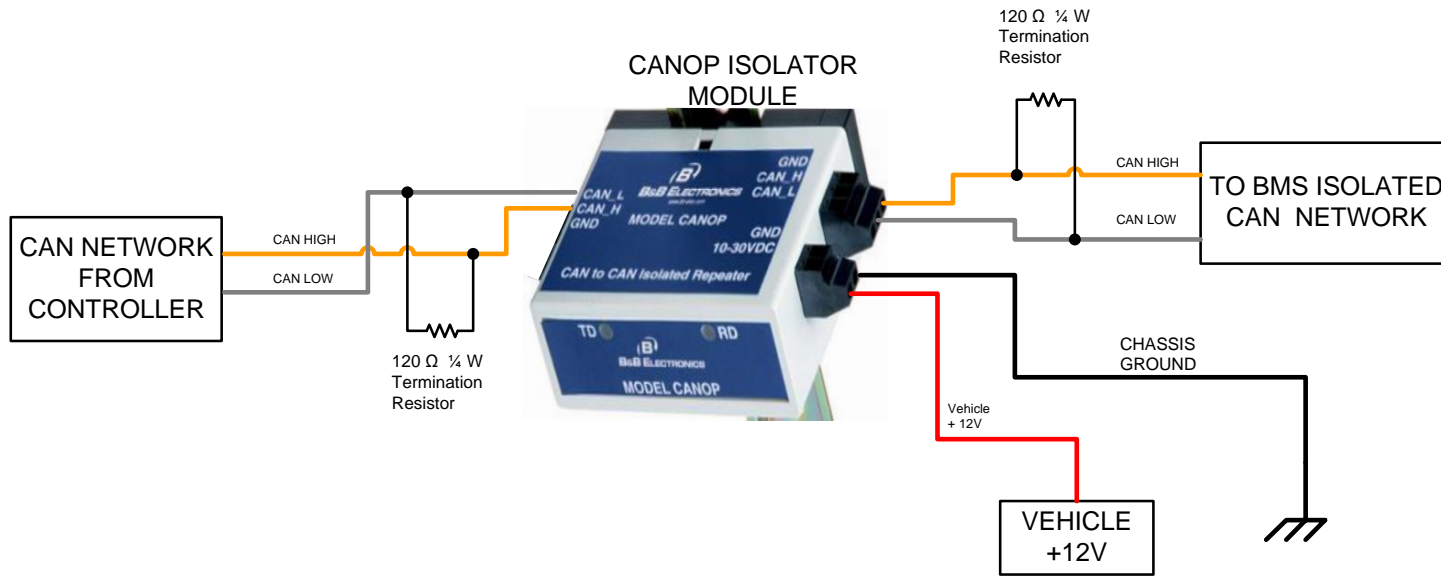

CAD TYPE	CAD LOC.	CAD FILE	DRW SIZE A
VISIO	UNIT	DRAWING 1010-CAN-OP-ISOLATOR	
DESIGN	DETAIL	TITLE	
CHECKED	SAFETY	CAN ISOLATOR	
SCALE	DATE	REVISION B	HPEVS
NONE	4/17/13	SHEET 1 OF 1	

NOTICE: This drawing is the property of Hi Performance Electric Vehicle Systems Inc., and/or its subsidiaries and affiliates (individually and collectively "HPEVS"), and contains highly proprietary, confidential, and trade secret information of HPEVS. The recipient of this drawing agrees (a) to use the information contained herein for the purpose for which it was furnished by HPEVS (b) to return this drawing upon HPEVS request. This notice shall appear on any complete or partial reproduction of this drawing.

REVISIONS		
REV	DESCRIPTION	APPROVED
A	INITIAL RELEASE	3/1/2013
B	Revision for clarification	10/30/2013

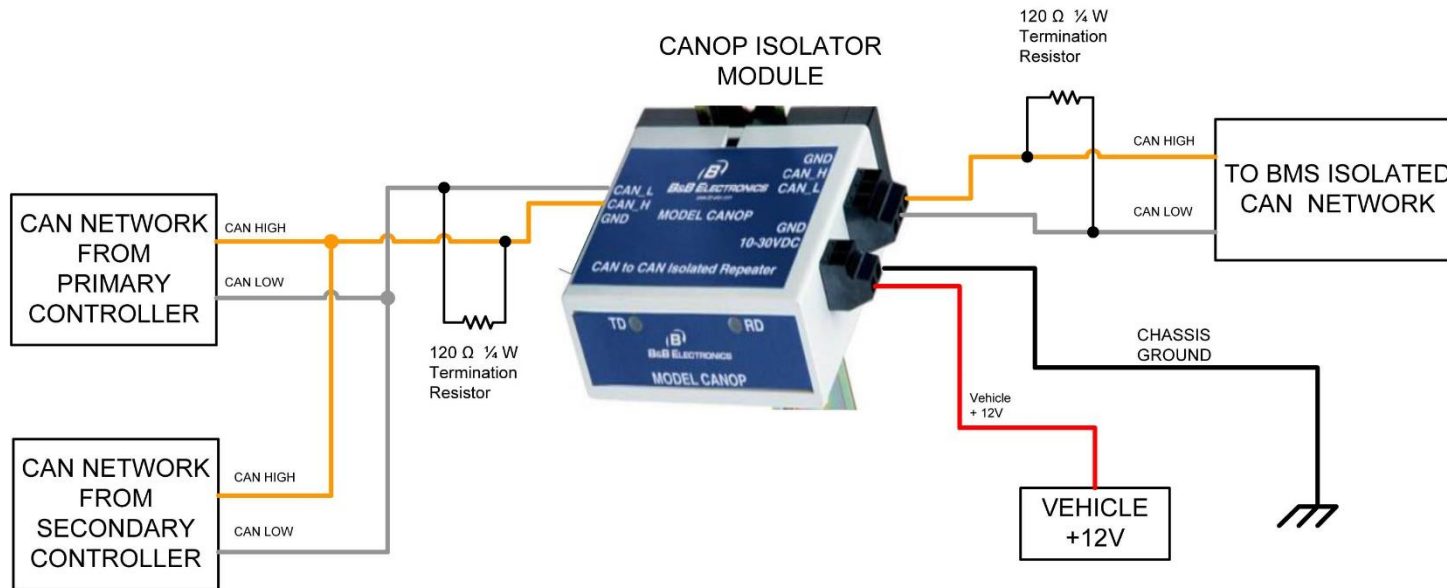

CAD TYPE VISIO	CAD LOC.	CAD FILE	DRW SIZE A
OPER. NO.	UNIT	DRAWING 1010-CAN-OP-ISOLATOR	
DESIGN	DETAIL	TITLE	
CHECKED	SAFETY	CAN ISOLATOR DUAL 1238 CONTROLLER	
SCALE NONE	DATE 4/17/13	REVISION B SHEET 1 OF 1	HPEVS

Program Entries Generic 530 (Parameters)							
Level 1	Parameter	Level 2	Parameter	Units	Parameter Range	Default Setting	Notes
User Settings							
		Speed Settings					
			Forward Speed	RPM	200 to 8500	6500	Defines the maximum requested motor rpm at full throttle with forward selected.
			Reverse Speed	RPM	200 to 8500	6500	Defines the maximum requested motor rpm at full throttle with reverse selected.
			Econo Speed	RPM	200 to 8500	6500	Defines the maximum requested motor rpm at full throttle with econo mode on.
		Accel Rates					
			Normal Accel Rate	Seconds	0.1 to 5.0	0.4	Sets the rate (in seconds) at which the speed command increases when throttle is applied. Larger values represent slower response.
			Econo Accel Rate	Seconds	0.1 to 5.0	0.5	Sets the rate (in seconds) at which the speed command increases in econo mode when throttle is applied. Larger values represent slower response.
		Throttle Settings					
			Throttle Type	N/A	1 to 3	3	The Curtis controllers accept a variety of throttle inputs. The throttle type parameter can be programmed as follows: 1= Electronic throttle (NO switch, 0-5 volt). 2: 2-wire rheostat, 0-5kΩ input 3: single-ended 3-wire 0-5kΩ potentiometer, or 0-5V voltage source or Electronic (Default)
			Deadband	Volt	0.00 to 5.00	.30	Defines the wiper voltage at the throttle deadband threshold. Increasing the throttle deadband setting will increase the neutral range.
			Throttle Max	Volt	0.00 to 5.00	3.5	Defines the wiper voltage required to produce 100% controller output. Decreasing the throttle max setting reduces the wiper voltage and therefore the full stroke necessary to produce full controller output.
			Mapped Throttle	%	0 to 100	50	Modifies the vehicle's response to the throttle input. Setting the throttle map at 50% provides a linear output response to throttle position. Values below 50% reduce the controller output at low throttle settings, providing enhanced slow speed maneuverability. Values above 50% give the vehicle a faster, more responsive feel at low throttle settings.
		Brake Pedal Settings					
			Brake Type		0 to 3	0	Select the brake type that is being utilized for the application being installed. The selection availability is as follows: a) Type 0= No Brake input used (Default) b) Type 1= 3-wire pot or an electronic (includes transducer or hall sensor.) c) Type 2= 2 wire 0 to 5k pot. d) Type 3= Switch
			Brake Deadband	Volt	0.00 to 5.00	0.30	Defines the wiper voltage at the brake deadband threshold. Increasing the brake deadband setting will increase the neutral range.
			Brake Max	Volt	0.00 to 5.00	3.50	Defines the wiper voltage required to produce 100% controller output. Decreasing the brake max setting reduces the wiper voltage and therefore the full stroke necessary to produce full controller output.
			Regen Brake Light Threshold	AMP	0 to 400	50	Allows for turning on the brake lamp based on the amount of regenerative braking that is taking place when off of the throttle. A higher number to this parameter means that there has to be a high amount of regen to be taking place to turn on the brake lamp
		Current Limits					
			Normal Neutral Braking	%	0 to 100	15	This parameter will allow for adjustment to Neutral Braking.
			Econo Neutral Braking	%	0 to 100	25	This parameter will allow for adjustment to Neutral Braking in economy mode.
			Shift Neutral Braking	%	0 to 100	7	Adjustment to neutral braking while pressing the clutch to shift a manual transmission
			Normal Drive Current Limit	%	5 to 100	100	Normal Drive Current Limit sets the maximum RMS current the controller will supply to the motor during drive operation, as a percentage of the controller's full rated current in normal operating mode. Reducing this value will reduce the maximum drive torque.
			Econo Drive Current Limit	%	5 to 100	60	Sets the maximum RMS current the controller will supply to the motor during drive operation, as a percentage of the controller's full rated current in economy operating mode. Reducing this value will reduce the maximum drive torque.
			Brake Current Limit	%	5 to 100	10	Sets the maximum RMS regen current during braking when a brake command is given, as a percentage of the controller's full rated current. Typically the brake current limit is set equal to the regen current limit. The brake current limit overrides the regen current limit when the brake input is active.

Level 1	Parameter	Level 2	Parameter	Units	Parameter Range	Default Setting	Notes
		Idle Setup					
			Idle Enable		On/Off	Off	on = motor idle will be turned on
			Clutch Start Enable		On/Off	Off	Enables clutch switch so that clutch needs to be depressed to start vehicle
			Idle Speed	RPM	300 to 1000	600	motor idle speed
			Idle Torque	%	0 to 100	50	percentage of available torque at idle speed
			Creep Torque	%	0 to 100	0	Creep torque available when Idle is set to OFF. Allows for the amount of torque applied when the vehicle when at a stop and no throttle input
		Motor Tuning					
			Motor Type		9 to 77	Based on motor type	Input motor type
			Base Speed	RPM	200 to 6000	3500	The speed set point for which the motor goes into field weakening.
			Field Weakening	%	0 to 100	50	Determines the amount of high speed power the controller will allow, while still maintaining maximum efficiency at the allowed power. Reducing this parameter effectively reduces controller current at high speeds, which can reduce energy consumption and motor heating, but at the expense of reduced available torque from the motor.
			Econo Field Weakening	%	0 to 100	0	Determines the amount of high speed power the controller will allow while in econo mode, while still maintaining maximum efficiency at the allowed power. Reducing this parameter effectively reduces controller current at high speeds, which can reduce energy consumption and motor heating, but at the expense of reduced available torque from the motor.
			Weakening Rate	%	0 to 100	36	Determines the control loop gains for field weakening. Setting the rate too low may create surging in the vehicle as it accelerates at mid to high speeds. Setting the rate too high may create high frequency oscillations (usually audible) when the vehicle accelerates at mid to high speeds.
		Main Contactor					
			Main Contactor Voltage	Volt	12 to 96	24	Main contactor voltage that is used in the system
			Main Holding %	%	0 to 100	80	The main contactor holding voltage parameter allows a reduced average voltage to be applied to the contactor coil once it has closed. This parameter must be set high enough to hold the contactor closed
		Display Menu Items					
			Auto Scroll	N/A	On/Off	Off	Turn on auto scroll function on 840 display to show monitored items listed below
			Scroll Delay Time	Seconds	1 to 10	4	Time that delays scroll function displaying the menu items below on the Spyglass 840
			Display SOC	N/A	On/Off	Off	When turned on the State Of Charge (SOC) of battery pack will be displayed. Acuity required.
			Display Motor RPM	N/A	On/Off	On	When turned on the Motor RPM will be displayed
			Display Battery Amps	N/A	On/Off	On	When turned on, battery pack current will be displayed
			Display Voltage	N/A	On/Off	On	When turned on, battery pack voltage will be displayed
			Display Motor Temp	N/A	On/Off	On	When turned on, motor temperature will be displayed
			Display Controller Temp	N/A	On/Off	On	When turned on, controller temperature will be displayed
			Display Minimum Voltage	N/A	On/Off	On	When turned on, minimum voltage during operation will be displayed
			Display Maximum Current	N/A	On/Off	On	When turned on, maximum current during operation will be displayed
		BMS					
			BMS Installed		On/Off	Off	When on can be used with Orion BMS. BMS must have CAN messages configured.
			BMS Address		768 to 1536	768	BMS Address range in decimal. Hex range = 0x300 to 0x600
			User Undervoltage	%	50 to 90	80	The value of this parameter is a percentage of the Nominal Voltage setting. The User Undervoltage parameter can be used to adjust the undervoltage threshold, which is the voltage at which the controller will cut back drive current to prevent damage to the electrical system.
			Low Cell Begin Cutback	Volt	0.000 to 4.000	2.800	Low cell cutback begin sets the voltage of the lowest cell where current limiting will begin
			Low Cell Full Cutback	Volt	0.000 to 4.000	2.300	Low Cell Full Cutback parameter sets the voltage of the lowest cell where full current limiting is in force
			Max Current at Full Cutback	%	0 to 100	50	Maximum Current Full Cutback parameter sets the maximum current allowed when low voltage full cutback is in force
			Maximum Cell Voltage	Volt	2.000 to 4.000	3.700	Maximum cell voltage parameter sets the voltage at which regen is turned off to prevent overcharging
			Low SOC Cutback	%	0 to 100	20	Low SOC (State of Charge) Cutback parameter sets the SOC at which current limiting is in force
			Max Current at Low SOC	%	0 to 100	30	Maximum Current Low SOC (State of Charge) parameter sets the maximum current allowed when SOC is lower than Low SOC Cutback

Level 1	Parameter	Level 2	Parameter	Units	Parameter Range	Default Setting	Notes
		Dual Drive					
			Dual Drive Mode		On/Off	Based on using either single motor or dual motor	This parameter turns dual drive off or on. Turn on for a dual motor.
			Response Timeout	ms	50 to 1000	200	Time allotted for the secondary controller(s) to respond to the primary controller
		Misc					
			Max Output Frequency	Hz	0 to 4000	266	Tachometer frequency allows the user to set-up the vehicles tachometer to work correctly based on the number of cylinders the original internal combustion engine had that was removed from the vehicle
			Prg Mode Step Timer	Seconds	1.0 to 10.0	4.0	The time in seconds that the program steps through program mode.
			Generic CAN Message ID Dec		1537 to 1616	1537	CAN ID that the controller transmits. Hex range = 0x601 to 0x650
		Software Version					
			VCL Version		0 to 32767	Based on VCL software version	Software Version
			OS Version		0 to 32767	Based on Operating system installed	Version number of the operating system software that is loaded into the controller. This variable specifies the major version number of the controller's operating system.
			OS Build Number		0 to 32767	Based on software OS Build system	Build number of the operating system software that is loaded into the controller.

Generic 530 Software Monitor Items						
Level 1	Parameter	Level 2	Parameter	Units	Parameter Range	Notes
Dual Drive						
	Dual Drive State				On/Off	On = A secondary controller has been detected in a dual drive system
CAN Communication						
	BMS Communicating				On/Off	On = BMS is communicating to the controller through the CAN Bus
	Charger Communicating				On/Off	On = Charger is communicating to the controller through the CAN Bus
Battery Information						
		Peak I&E				
			Peak RMS Current	AMP	0 to 1000	Peak RMS current reported while the system is under load
			Minimum Voltage	Volt	0 to 170.0	Minimum voltage reported while the system is under load
		General				
			Keyswitch Voltage	Volt	0 to 150	Voltage at KSI (Pin 1)
			Measured Current	AMP	-600 to 600	The Measured System Current During Operation
			Remaining Amphours	AMP	0 to 500	Remaining Battery Amphours
			BDI Percentage	%	0 to 100	Battery state of charge.
			Aux Battery Voltage	Volt	0 to 20	Auxiliary battery voltage
		Charging Info				
			Charger Output Current	Amperes	0 to 100	Battery charger output current to the battery pack
			Charger Output Voltage	Volt	0 to 1400	Battery charger output voltage to the battery pack
			Charger Status	N/A	0 to 32	Status of the charger.
		Cell Monitor				
			Highest Cell			Identification of the battery with the highest voltage
			Highest Cells Voltage	Volt	0 to 4.500	Highest battery cell voltage
			Lowest Cell			Identification of the battery with the lowest voltage
			Lowest Cells Voltage	Volt	0 to 4.500	lowest battery cell voltage
			Highest Temperature	°C		Highest battery temperature within the battery pack
			Lowest Temperature	°C		Lowest battery temperature within the battery pack

GLOSSARY OF TERMS

1. **Accel Rate:** sets the rate (in seconds) at which the motor torque increases to full when full throttle is applied. Larger values represent slower response.
2. **Baud rate:** a unit used to measure the speed of electronic code transmission, equal to one-unit interval per second.
3. **BMS:** Battery Management System
4. **Brake Current Limit:** Sets the maximum RMS regen current during braking when a brake command is given, as a percentage of the controller's full rated current. The full rated current depends on the controller model.
5. **Brake Input Rate:** Sets the rate (in seconds) at which the vehicle slows down when brake is applied or when throttle is applied in the opposite direction. Larger values represent slower response.
6. **Brake Maximum:** Defines the input voltage required to produce 100% braking torque. Decreasing the brake max setting reduces the amount of voltage necessary to produce full braking torque.
7. **Brake Type:** Defines the brake input for the controller:
 - a. **Type 2**= 3 wire 0 to 5kohm pot or electronic 0-5v input or pressure transducer.
 - b. **Type 3**= 2 wire with switch; 0 to 5kohm.
 - c. **Type 5**= switch.
8. **CAN:** Controller Area Network. A vehicle bus standard designed to allow microcontrollers and devices to communicate with each other within a vehicle. All controllers on the CAN bus need to have the Baud Rate set the same.
9. **Creep Torque:** Determines the amount of torque applied to the vehicle at a stop with no throttle input, to emulate the feel of an automatic transmission automobile. **WARNING!** When interlock is engaged, creep torque allows vehicle propulsion if a direction is selected even though no throttle is applied. Care should be taken when setting up this parameter. If pedal braking is enabled, creep torque is progressively disabled as brake is applied so as to prevent the motor from driving into the brakes and thus wasting energy.
10. **Deadband:** is an area of a signal range or band where no action occurs (the system is dead).
11. **EncA & B:** two signals from the encoder for which the controller determines direction of rotation and speed of the motor.
12. **Field Weakening Rate:** Determines the control loop gains for field weakening. Setting the rate too low may create surging in the vehicle as it accelerates at mid to high speeds. Setting the rate too high may create high frequency oscillations (usually audible) when the vehicle accelerates at mid to high speeds.
13. **Generic CAN Message:** CAN message containing general information regarding the status of the motor and controller.
14. **Idle Torque:** Torque load delivered by the motor at idle. If the Idle for the motor is enabled, idle torque will equal creep torque.

15. **Load Meter:** The LED lights that are located on the bottom of the Spyglass represent how much of a load is exerted on the system.
16. **Neutral Braking:** Neutral braking occurs progressively when the throttle is reduced toward the neutral position or when no direction is selected. The neutral braking parameter is adjustable from 0 to 100% of the regen current limit.
17. **Nominal Voltage:** Battery pack voltage; not to exceed controller voltage ratings.
18. **Regenerative Braking:** Regenerative braking is used on electric vehicles to recoup some of the energy lost during stopping. This energy is saved to the batteries and used later to power the motor to put the car in motion.
19. **Shift Neutral Braking:** Adjustment to neutral braking while pressing the clutch to shift a manual transmission
20. **SOC:** State of charge.
21. **Spyglass:** Name given by Curtis Instruments to the 8 segment LCD, 5-LED display.
22. **Throttle Maximum:** Defines the wiper input voltage required to produce 100% controller output. Decreasing the throttle max setting reduces the amount of voltage necessary to produce full controller output.
23. **Throttle Type:** Defines the throttle input for the controller:
 - a. **Type 1**= Electronic without switch
 - b. **Type 2**= 0-5K ohm 2 wire pot with switch.
 - c. **Type 3**= 0-5K ohm 3-wire pot with switch. Electronic with switch.

NOTICE: This drawing is the property of Hi Performance Electric Vehicle Systems Inc., and/or its subsidiaries and affiliates (individually and collectively "HPEVS"), and contains highly proprietary, confidential, and trade secret information of HPEVS. The recipient of this drawing agrees (a) to use the information contained herein for the purpose for which it was furnished by HPEVS (b) to return this drawing upon HPEVS request. This notice shall appear on any complete or partial reproduction of this drawing.

CONNECT TO PRIMARY HARNESS AT MOTOR ENCODER CONNECTORS P4 & P4B

R4
DEUTSCH
DTM-06-4S

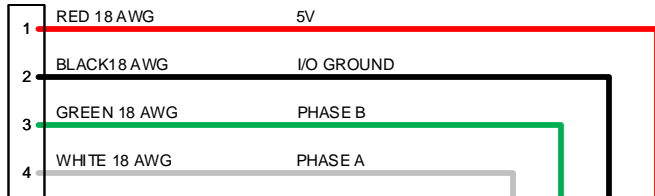

R4B
DEUTSCH
DTM-06-2S

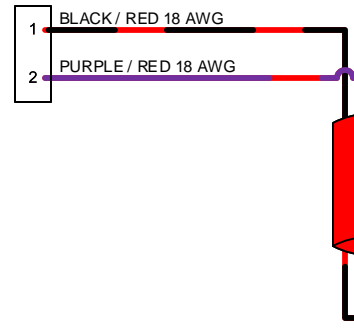

P9
DEUTSCH
DTM-04-6P

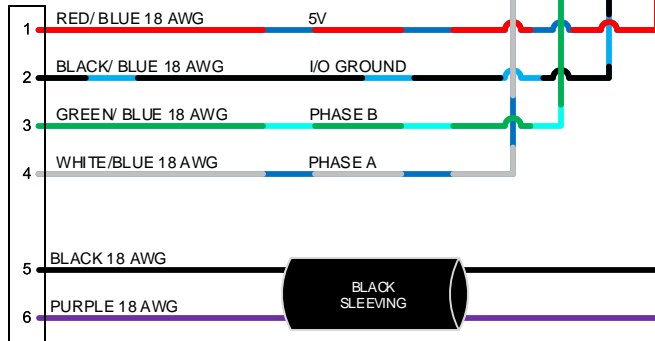

CONNECT TO SECONDARY HARNESS AT MOTOR ENCODER CONNECTOR R9

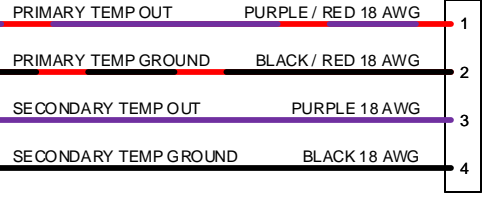
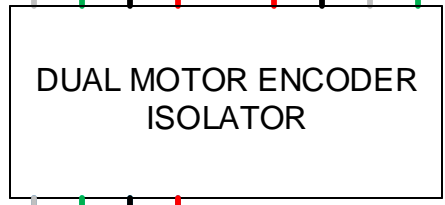

P7
DEUTSCH
DTM-04-4P

CONNECT TO MOTOR ENCODER

R8
DEUTSCH
DTM-06-4S

CONNECT TO MOTOR TEMPERATURE

CAD TYPE VISIO	CAD LOC.	APPLICABLE SOFTWARE	DRW SIZE B
OPER. NO.	UNIT	DRAWING 1010-DUAL-ENCODER-ISOLATOR	
DESIGN	DETAIL	TITLE DUAL MOTOR ENCODER ISOLATOR SCHEMATICS	
CHECKED	SAFETY		
SCALE NONE	DATE 3/28/19	REVISION C	HPEVS
		SHEET 1 OF 1	