



Hi Performance Electric Vehicle Systems

620 S. Magnolia Avenue

Suite B

Ontario, CA 91762

(909) 923-1973

## Electrical Schematics and Documentation

**FOR CURTIS 1232-1238 "E" AND "SE"**

**VERSION CONTROLLERS**

**SOFTWARE VERSIONS 5.32 AND HIGHER**

**FOR SINGLE AND DUAL MOTOR**

**APPLICATIONS**

**Date 04-29-21**

Table of Contents

**Quick Start Electrical Schematics.....3**

**Full Electrical Schematics 1232-1238 “E” and “SE” Controllers.....8**

**Throttle Configuration.....13**

**Type 1 Electronic without switch.....14**

**Type 1 Curtis Electronic Throttle Model ET-126 or ET-134 without switch...15**

**Type 2 2-Wire Pot.....16**

**Type 3 3-Wire Pot.....17**

**Type 3 Curtis PB-8 Throttle Assembly.....18**

**Type 3 Curtis Electronic Throttle Model ET-126 or ET-134.....19**

**Type 4 3-Wire Wigwag.....20**

**Throttle Interlock Connection.....21**

**Brake Input Configuration.....22**

**Type 1 Pressure Transducer or Electronic or 3-Wire Pot.....23**

**Type 2 2-Wire Pot.....24**

**Brake Light Configurations.....25**

**CAN-OP Isolator Modules.....29**

**Dual Motor Encoder Isolator.....31**

**Program Entries (Parameters).....32**

**Additional Notes.....35**

**Monitor Items.....36**

**Orion BMS Information.....37**

**Orion BMS Byte Structure.....40**

**Fault Codes.....41**

**Glossary of Terms.....65**

# **QUICK START GENERIC ELECTRICAL SCHEMATICS**

## **1232-1238 “E” and “SE” CONTROLLERS**

The following quick start electrical schematics for both single and dual motor configurations have been generated to assist in quickly getting the drive system connected and running.

**NOTICE:** This drawing is the property of HiPerformance Electric Vehicle Systems Inc. and/or its subsidiaries and affiliates (individually and collectively "HPEVS"), and contains highly proprietary, confidential, and trade secret information of HPEVS. The recipient of this drawing agrees (a) to use the information contained herein for the purpose for which it was furnished by HPEVS (b) to return this drawing upon HPEVS request. This notice shall appear on any complete or partial reproduction of this drawing.

REVISIONS		
REV	DESCRIPTION	APPROVED
A	Initial Release	4/18/2016
B	Corrected Encoder Cable Connectors	4/28/2021

## QUICK START SCHEMATIC FOR SINGLE MOTOR OR PRIMARY MOTOR IN DUAL MOTOR CONFIGURATION CURTIS 1232 / 1234 / 1236 / 1238 "E" AND "SE" CONTROLLERS

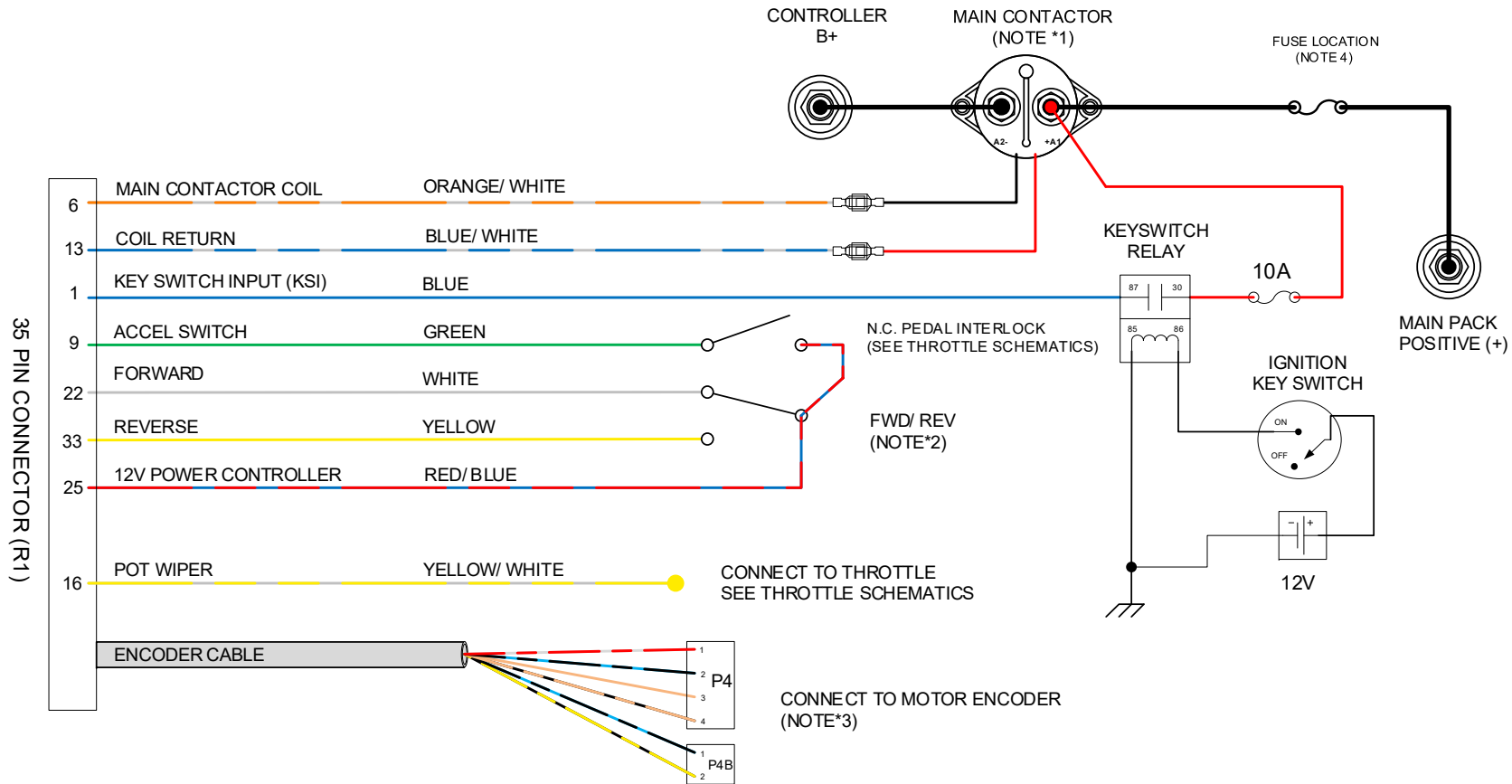

### NOTES:

- (1) Use supplied contactor.
- (2) Forward is CLOCKWISE motor rotation from **encoder end view**. Depending on transmission configuration, use either wire to obtain desired rotation. Use FWD & REV switch in direct drive applications.
- (3) For dual motor application, see dual motor encoder isolator schematics on Page 31 for more details.
- (4) Use suitable rated fuse. For dual motor application, each controller must be fused.

CAD TYPE VISO	APPLICABLE SOFTWARE	VERSION 5.32 & UP
UNIT NONE	DRAWING	1010-1232_38-QS-E-GEN-365
DRW SIZE A	TITLE	QUICK START SCHEMATIC FOR 1232-1238 "E" AND "SE" CONTROLLERS
DATE 4/26/21		
SUPPLIER PART		
SCALE NONE	SHEET 1 OF 1	REVISION B HPEVS

**Quick Start Electrical Schematic Generic 532 Software Pin Out Specific for 1232-1238 "E" AND "SE" Controllers Single Motor or Primary in Dual Motor Applications**

<b>Pin #</b>	<b>Name</b>	<b>Function</b>	<b>Terminations</b>	<b>Wire color</b>	<b>Detailed Description</b>
<b>1</b>	KSI	Keyswitch_Input		Blue	<b>Keyswitch input. Provides logic power for the controller and power for the coil drivers.</b>
<b>6</b>	Driver 1	Main_Contactor		Orange/White	<b>Main Contactor Coil Driver.</b>
<b>9</b>	Switch 3	Accel_Switch_Input	Active high, connect to 12 volts. See schematic	Green	<b>Used as safety interlock; switch is open when throttle switch is released. Type 2 &amp; 3 throttle only.</b>
<b>13</b>	Coil Return	Coil Return	Common to all relay coils	Blue/White	<b>This is the coil return pin (at B+ potential) for all the contactor and relay coils.</b>
<b>16</b>	Throttle Pot Wiper	Pot Wiper		Yellow/White	<b>Wiper or throttle input.</b>
<b>22</b>	Switch 7	Forward_Switch_Input	Active high, connect to KSI to activate.	White	<b>Used by the Motor Control to select forward direction</b>
<b>25</b>	+12V Out			Red/Blue	<b>Unregulated low power +12V output.</b>
<b>33</b>	Switch 8	Reverse_Switch_Input	Active high, connect to KSI to activate.	Yellow	<b>Used by the Motor Control to select reverse direction</b>

**NOTICE:** This drawing is the property of HiPerformance Electric Vehicle Systems Inc., and/or its subsidiaries and affiliates (individually and collectively "HPEVS"), and contains highly proprietary, confidential, and trade secret information of HPEVS. The recipient of this drawing agrees (a) to use the information contained herein for the purpose for which it was furnished by HPEVS (b) to return this drawing upon HPEVS request. This notice shall appear on any complete or partial reproduction of this drawing.

REVISIONS		
REV	DESCRIPTION	APPROVED
A	Initial Release	4/ 18/ 2016

## QUICK START SCHEMATIC FOR SECONDARY MOTOR CONFIGURATION CURTIS 1232 / 1234 / 1236 / 1238 "E" CONTROLLERS

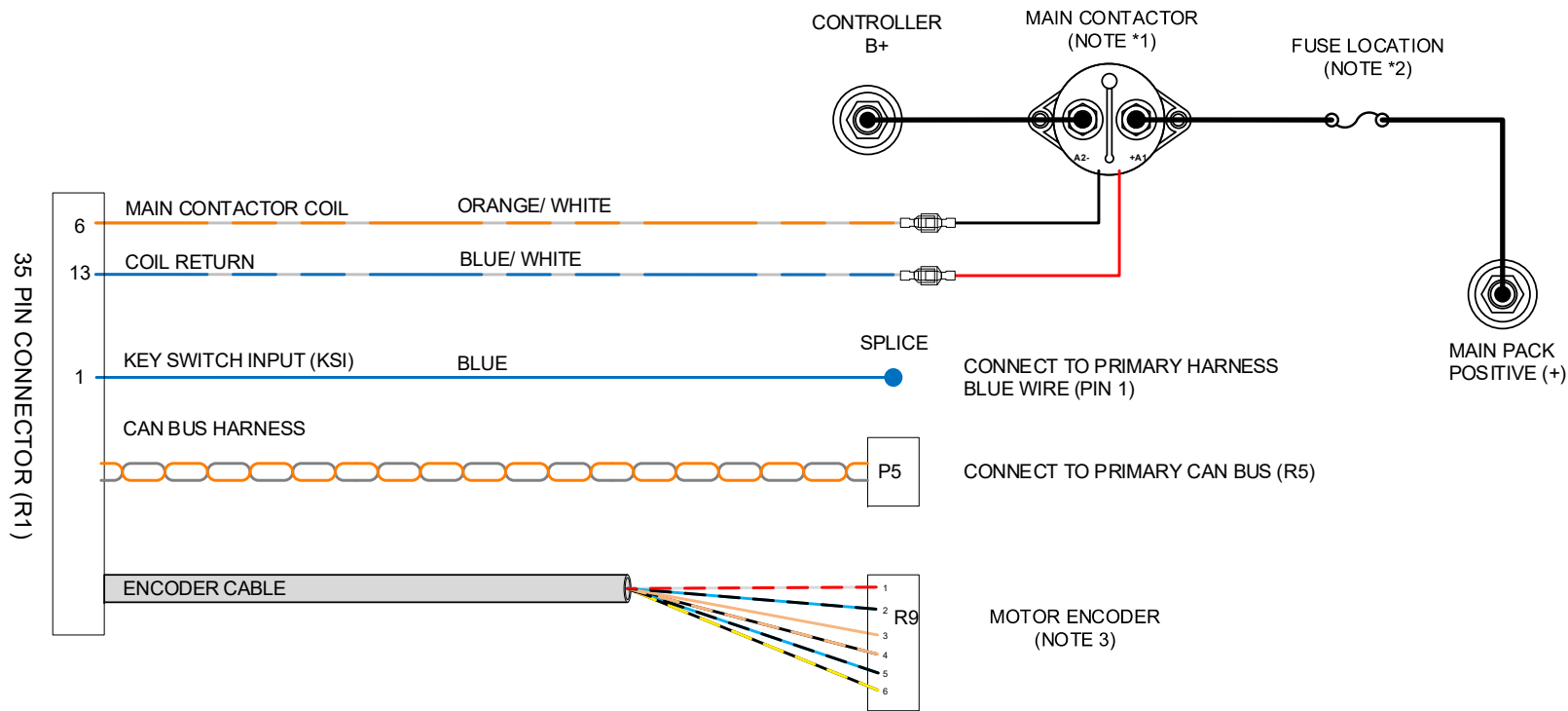

### NOTES:

(\*1) **USE SUPPLIED CONTACTOR**

(\*2) USE SUITABLE RATED FUSE. FOR DUAL MOTOR APPLICATION, EACH CONTROLLER MUST BE FUSED.

(3) Encoder isolator **MUST BE USED**. See encoder Isolator schematics on Page 31 for more details

CAD TYPE VISIO	APPLICABLE SOFTWARE VERSION 365.10 & UP
UNIT NONE	DRAWING 1010-1232_38-QS-SEC-E-GEN-365
DRW SIZE A	TITLE QUICK START SCHEMATIC FOR SECONDARY 1232-1238 "E" CONTROLLERS
DATE 3/28/19	
SUPPLIER PART	
SCALE NONE	SHEET 1 OF 1
REVISION C	HPEVS

**Quick Start Electrical Schematic Generic Software Pin Out Specific for 1232-1238 "E" AND "SE" Secondary Controller in Dual Motor Applications**

Pin #	Name	Function	Terminations	Wire color	Detailed Description
<b>1</b>	KSI	Keyswitch_Input		Blue	<b>Keyswitch input. Provides logic power for the controller and power for the coil drivers. Connect to primary harness at the Blue KSI wire.</b>
<b>6</b>	Driver 1	Main_Contactor		Orange/White	<b>Main Contactor Coil Driver.</b>
<b>13</b>	Coil Return	Coil Return	Common to all relay coils	Blue/White	<b>This is the coil return pin (at B+ potential) for all the contactor and relay coils.</b>

**FULL ELECTRICAL SCHEMATICS**  
**CURTIS 1232-1238 "E" AND "SE" CONTROLLERS**



**NOTICE:** This drawing is the property of Hi Performance Electric Vehicle Systems Inc., and for its subsidiaries and affiliates (individually and collectively "HPEVS"), and contains highly proprietary, confidential, and trade secret information of HPEVS. The recipient of this drawing agrees (a) to use the information contained herein for the purpose for which it was furnished by HPEVS (b) to return this drawing upon HPEVS request. This notice shall appear on any complete or partial reproduction of this drawing.

REVISIONS		
REV	DESCRIPTION	APPROVED
A	Initial Release	4/11/2016
B	CORRECTED FUSE LOCATION	4/26/2021

## ELECTRICAL SCHEMATICS FOR SINGLE MOTOR OR PRIMARY MOTOR IN DUAL MOTOR CONFIGURATION 1232 / 1234 / 1236 / 1238 "E" CONTROLLERS

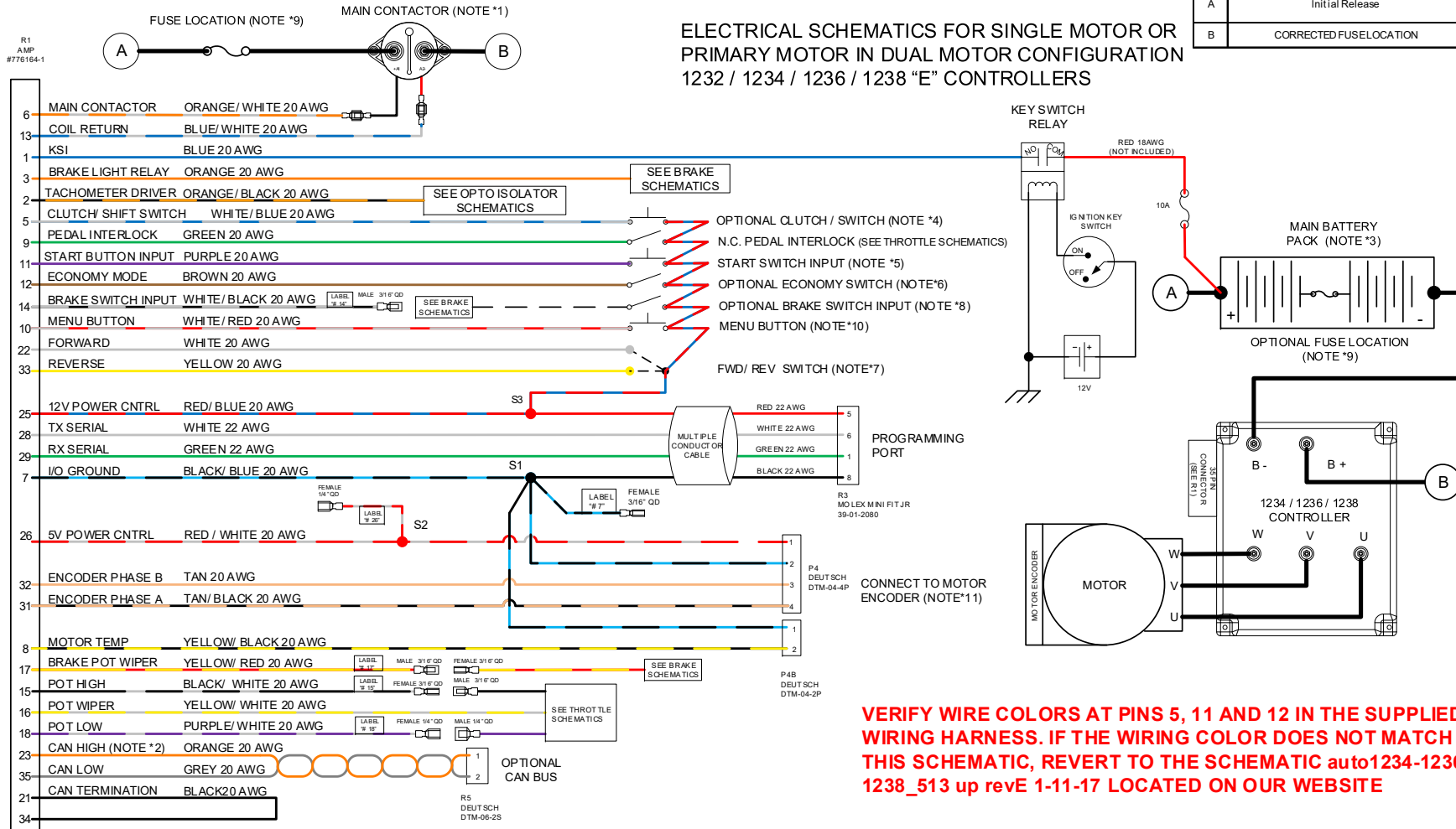

**VERIFY WIRE COLORS AT PINS 5, 11 AND 12 IN THE SUPPLIED WIRING HARNESS. IF THE WIRING COLOR DOES NOT MATCH THIS SCHEMATIC, REVERT TO THE SCHEMATIC auto1234-1236-1238\_513 up rev E 1-11-17 LOCATED ON OUR WEBSITE**

(\*1) Use supplied Contactor (GIGAVAC Part #GV200QA-1). Use only a Contactor WITHOUT PWM AND COIL SUPPRESSION. FAILURE TO DO SO CAN CAUSE CONTROLLER FAILURE AND WILL VOID WARRANTY.

(\*2) The Controller CAN Communication needs to be isolated from other CAN based components. A CAN isolator may be needed. Possible source of CAN isolator is CANOP from B&B Electronics ([www.bb-elec.com](http://www.bb-elec.com))

(\*3) A Battery Management System (BMS) is strongly recommended if Lithium Ion batteries are used. Possible source of BMS is Ewert Energy System's ORION BMS ([www.orionbms.com](http://www.orionbms.com))

(\*4) Install the Clutch/ Shift Switch so that the signal is active high when the clutch pedal is pressed. When clutch pedal is pressed the Regen setting is changed to Shift Neutral Braking Parameter to prevent the motor from stalling during gear shifting. In a clutchless system, this allows you to set the coast down rate of the motor so that the gears align properly See Instructions on SHIFT-NEUTRAL BRAKING PARAMETERS.

(\*5) Start switch required if Idle function or creep torque is turned ON.

(\*6) Allows the use of ECONO Mode Parameters. See Programming Instructions.

(\*7) Forward is CLOCKWISE motor rotation from Encoder end view. Depending on Transmission configuration, use either wire to obtain desired rotation. Use FWD & REV Switch in direct drive applications.

(\*8) See Brake Schematics.

(\*9) Use suitable rated fuse. For Dual Motor application, each controller must be fused.

(\*10) Gives access to Drive System information. Required to access Programming and Diagnostic modes. See Programming Instructions.

(\*11) For dual motor application, see dual motor encoder isolator schematics on Page 31 for more details.

CAD TYPE	APPLICABLE SOFTWARE	Version 5.32 & Up	
VISIO	DRAWING	1010-AUTO-CONVERSION-VER365	
UNIT	NONE	1010-AUTO-CONVERSION-VER365	
DRWSIZE	A	TITLE "E" CONTROLLER ON-ROAD VEHICLE CONVERSION / PRIMARY MOTOR SCHEMATICS	
DATE	4/26/21		
SUPPLIER PART	HW-AUTOCONVERSION-HPG		
SCALE	SHEET 1 OF 1	REVISION	B HPEVS

**Generic Software 538 Switch Pin Out Specific for 1232-1238 "E" AND "SE" Single Motor or Primary in Dual Motor Applications**

Pin #	Name	Function	Terminations	Wire color	Detailed Description
1	KSI	Keyswitch_Input		Blue	Keyswitch input. Provides logic power for the controller and power for the coil drivers.
2	Prop. Driver	Tachometer Driver		Orange/Blk	Digital output used to drive a tachometer
3	Driver 4	Brake Light Relay		Orange	Brake light relay driver
4	N/C				
5	Switch 10	Clutch/Shift Switch		Wht/Blue	Switch input is used to reduce neutral braking while shifting
6	Driver 1	Main_Contactor		Orange/Wht	Main Contactor Coil Driver.
7	I/O Ground			Black/Blue	Input and output ground reference.
8	Analog 2	Motor_Temperature_Sensor		Yellow/Black	Used as the motor temperature analog input
9	Switch 3	Accel_Switch_Input	Active high, connect to 12 volts. See schematic	Green	Used as safety interlock; switch is open when throttle switch is released. Type 2 & 3 throttle only.
10	Menu	Menu_Button	Active high, connect to 12 volts. See schematic	White/Red	Momentary switch; used to scroll through 840 spyglass display
11	Switch 5	Start_Switch_Input	Active high, connect to 12 volts. See schematic	Purple	Momentary switch; Enables drive system when Idle function is turned ON.
12	Switch 6	Economy_Mode_Switch_Input		Brown	Switch input used to activate Economy Mode.
13	Coil Return	Coil Return	Common to all relay coils	Blue/White	This is the coil return pin (at B+ potential) for all the contactor and relay coils.
14	Brake Switch Input	Brake_Sw		White/Black	Switch input used for brake rate.
15	Throttle Pot High	Pot High		Black/Wht	Pot high connection for a 3-wire throttle pot.
16	Throttle Pot Wiper	Pot Wiper		Yellow/Wht	Wiper or throttle input.
17	Pot2 Wiper	Brake Pot Wiper		Yellow/Red	Brake input.
18	Pot Low	Pot Low		Purple/Wht	Pot low connection for brake and throttle.
19	N/C				
20	N/C				
21	CAN Term H	CAN Termination		Black	CAN termination jumper.
22	Switch 7	Forward_Switch_Input	Active high, connect to KSI to activate.	White	Used by the Motor Control to select forward direction
23	CANH	CAN High		Orange	CAN bus high.
24	N/C				
25	+12V Out			Red/Blue	Unregulated low power +12V output.
26	+5V Out			Red/White	Regulated low power +5V output.
27	N/C				
28	Serial TX			White	Serial transmit line for display or flash update.
29	Serial RX			Green	Serial receive line for display or flash update.
30	N/C				
31	Encoder Phase A	MotorspeedA_Input		Tan/Black	Quadrature encoder input phase A
32	Encoder Phase B	MotorspeedB_Input		Tan	Quadrature encoder input phase B
33	Switch 8	Reverse_Switch_Input	Active high, connect to KSI to activate.	Yellow	Used by the Motor Control to select reverse direction
34	CAN Term L	CAN Termination		Black	CAN bus termination jumper.
35	CANL	CAN Low		Grey	CAN bus low.

**NOTICE:** This drawing is the property of Hi Performance Electric Vehicle Systems Inc. and/or its subsidiaries and affiliates (individually and collectively "HPEVS"), and contains highly proprietary, confidential, and trade secret information of HPEVS. The recipient of this drawing agrees: (a) to use the information contained herein for the purpose for which it was furnished by HPEVS (b) to return this drawing upon HPEVS request. This notice shall appear on any complete or partial reproduction of this drawing.

REVISIONS		
REV	DESCRIPTION	APPROVED
A	Initial Release	4/11/2016
C	CORRECTED FUSE LOCATION	4/26/2021

## DUAL MOTOR 1232 / 1234 / 1236 / 1238 "E" CONTROLLERS SECONDARY MOTOR ELECTRICAL SCHEMATICS

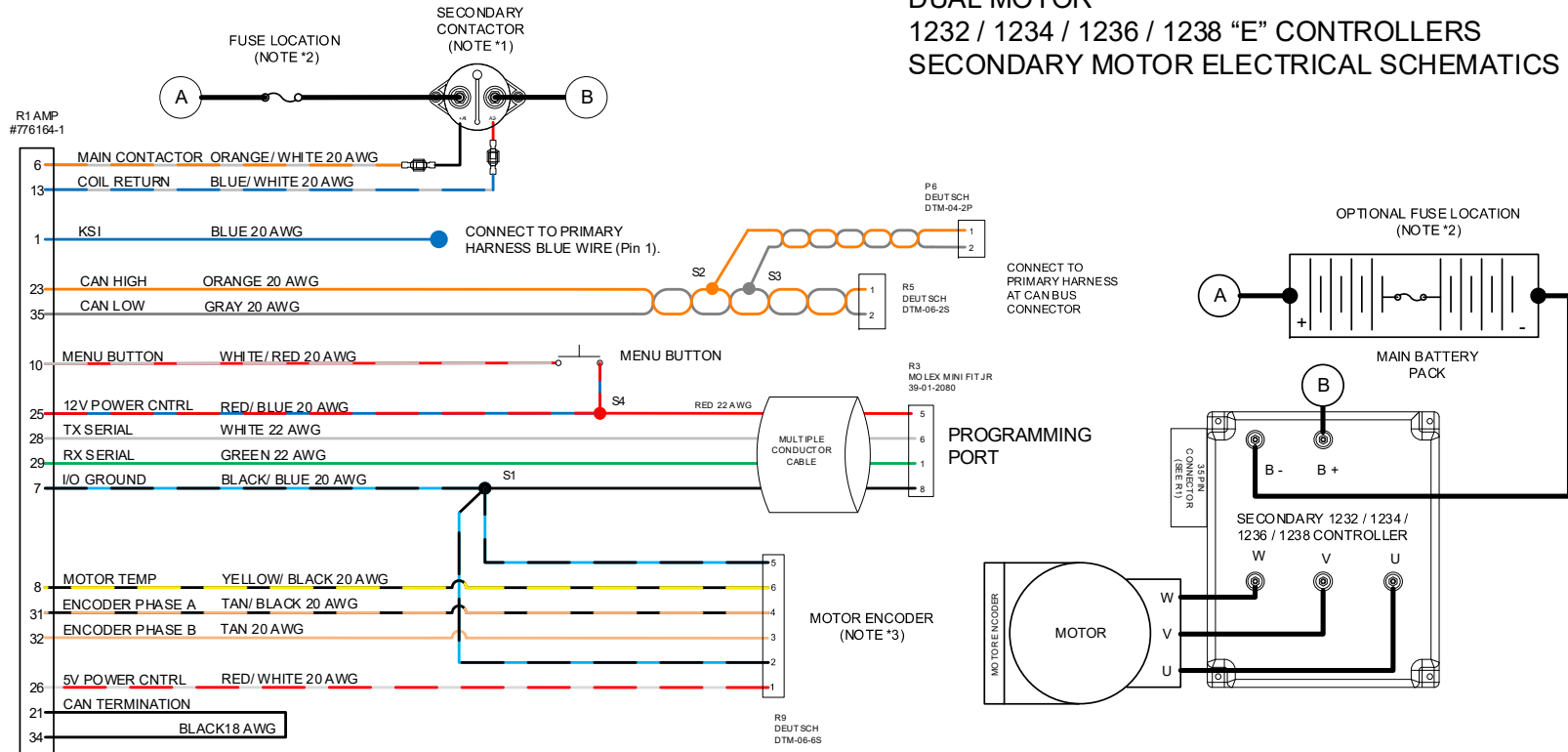

### NOTES:

- (1) Use supplied Contactor (GIGAVAC Part #GV200QA-1). Use only a Contactor WITHOUT PWM AND COIL SUPPRESSION. FAILURE TO DO SO CAN CAUSE CONTROLLER FAILURE AND WILL VOID WARRANTY.
- (2) USE SUITABLE RATED FUSE. FOR DUAL MOTOR APPLICATION, EACH CONTROLLER MUST BE FUSED.
- (3) Encoder isolator MUST BE USED. See encoder Isolator schematics on Page 31 for more details.

CAD TYPE VISO	APPLICABLE SOFTWARE	Version 5.32 & UP
UNIT NONE	DRAWING	1010-AUTO-CONVERSION-SEC-VER365
DRW SIZE A	TITLE	1232-1238 "E" CONTROLLER SECONDARY MOTOR SCHEMATICS
DATE 4/26/2021		
SUPPLIER PART	HW-1010AUTO-HPG	
SCALE none	SHEET 1 OF 1	REVISION C HPEVS

**Generic Software 538 Switch Pin Out Specific for 1232-1238 "E" AND "SE" Secondary Controller in Dual Motor Applications**

Pin #	Name	Function	Terminations	Wire color	Detailed Description
1	KSI	Keyswitch_Input		Blue	Keyswitch input. Provides logic power for the controller and power for the coil drivers. Connect to primary harness at the Blue KSI wire.
2	N/C				
3	N/C				
4	N/C				
5	N/C				
6	Driver 1	Main_Contactor		Orange/White	Main Contactor Coil Driver.
7	I/O Ground			Black	Input and output ground reference.
8	Analog 2	Motor_Temperature_Sensor		Blue	Used as the motor temperature analog input
9	N/C				
10	N/C				
11	N/C				
12	N/C				
13	Coil Return	Coil Return	Common to all relay coils	Blue/White	This is the coil return pin (at B+ potential) for all the contactor and relay coils.
14	N/C				
15	N/C				
16	N/C				
17	N/C				
18	N/C				
19	N/C				
20	N/C				
21	CAN Term H	CAN Termination		Black	CAN termination jumper.
22	N/C				
23	CANH	CAN High		Orange	CAN bus high.
24	N/C				
25	+12V Out			Red/Blue	Unregulated low power +12V output.
26	+5V Out			Red	Regulated low power +5V output.
27	N/C				
28	Serial TX			White	Serial transmit line for display or flash update.
29	Serial RX			Green	Serial receive line for display or flash update.
30	N/C				
31	Encoder Phase A	MotorspeedA_Input		White	Quadrature encoder input phase A
32	Encoder Phase B	MotorspeedB_Input		Green	Quadrature encoder input phase B
33	N/C				
34	CAN Term L	CAN Termination		Black	CAN bus termination jumper.
35	CANL	CAN Low		Grey	CAN bus low.

## THROTTLE CONFIGURATION

Depending on the type of throttle used for the application, the different types of throttle configurations are listed within the table below. Electrical schematics are also included within the following pages.

<b>THROTTLE CONFIGURATION</b>	<b>TYPE</b>
ELECTRONIC without SWITCH CURTIS ET-126/ET-134 ELECTRONIC THROTTLE ASSEMBLY without SWITCH	TYPE 1
2 WIRE with SWITCH 0-5k $\Omega$	TYPE 2
3 WIRE with SWITCH 0-5k $\Omega$	TYPE 3 Default
CURTIS PB8 THROTTLE ASSEMBLY	TYPE 3
CURTIS ET-126/ET-134 ELECTRONIC THROTTLE ASSEMBLY WITH SWITCH	TYPE 3
WIG WAG 3 WIRE	TYPE 4

**NOTICE:** This drawing is the property of Hi Performance Electric Vehicle Systems Inc., and/or its subsidiaries and affiliates (individually and collectively "HPEVS"), and contains highly proprietary, confidential, and trade secret information of HPEVS. The recipient of this drawing agrees (a) to use the information contained herein for the purpose for which it was furnished by HPEVS (b) to return this drawing upon HPEVS request. This notice shall appear on any complete or partial reproduction of this drawing.

REVISIONS		
REV	DESCRIPTION	APPROVED
A	INITIAL RELEASE	1/22/2013

## TYPE 1 ELECTRONIC THROTTLE

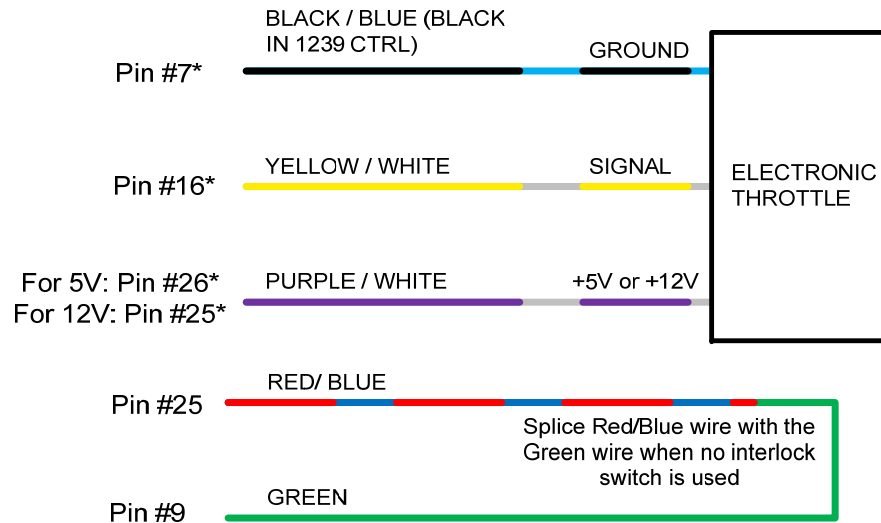

\* Typical connection, verify correct voltage and connection in throttle documents or instructions.

**Not all Electronic Throttles supported**

CAD TYPE VISIO	APPLICABLE SOFTWARE		
UNIT NONE	DRAWING 1010-THROTTLE-001		
DRW SIZE A	TITLE		
DATE 1/22/13	ELECTRONIC THROTTLE		
SUPPLIER PART			
SCALE NONE	SHEET 1 OF 1	REVISION A	HPEVS

NOTICE: This drawing is the property of H Performance Electric Vehicle Systems, Inc., and/or its subsidiaries and affiliates (individually and collectively "HPEVS"), and contains highly proprietary, confidential, and trade secret information of HPEVS. The recipient of this drawing agrees: (a) to use the information contained herein for the purpose for which it was furnished by HPEVS; (b) to return this drawing upon HPEVS request. This notice shall appear on any complete or partial reproduction of this drawing.

REVISIONS		
REV	DESCRIPTION	APPROVED
A	Initial Release	11/17/2015

### CURTIS ELECTRONIC THROTTLE MODEL NUMBERS ET-126 OR ET-134 TYPE 1 WITHOUT SWITCH

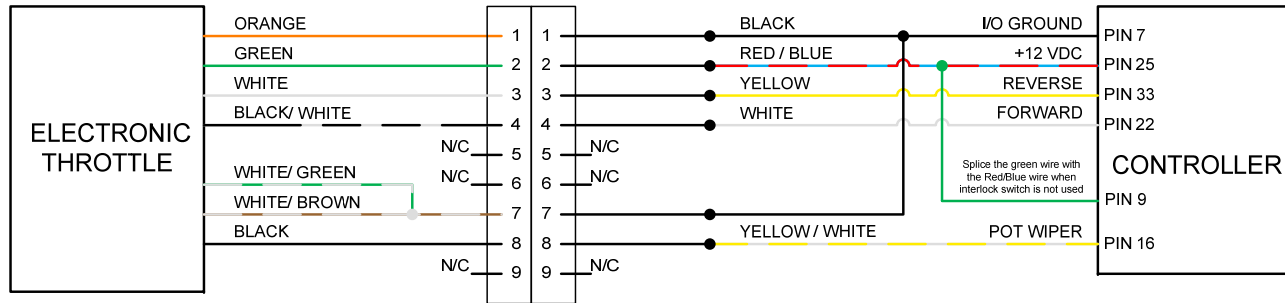

ET-126 HAS A SPRING RETURN SO THAT THE THROTTLE RETURNS TO NEUTRAL POSITION

ET-134 DOES NOT HAVE A SPRING RETURN

CAD TYPE	APPLICABLE SOFTWARE	VER 2.5
VISIO	DRAWING	1010-ETHrottle
UNIT	TITLE	
NONE	Curtis Electronic Throttle	
DRW SIZE	Part ET-126 OR ET-134	
A	Type 1	
DATE	SHEET 1 OF 1	
11/17/15	REVISION	A
SUPPLIER PART	HPEVS	
SCALE	none	

**NOTICE:** This drawing is the property of Hi Performance Electric Vehicle Systems Inc., and/or its subsidiaries and affiliates (individually and collectively "HPEVS"), and contains highly proprietary, confidential, and trade secret information of HPEVS. The recipient of this drawing agrees (a) to use the information contained herein for the purpose for which it was furnished by HPEVS (b) to return this drawing upon HPEVS request. This notice shall appear on any complete or partial reproduction of this drawing.

REVISIONS		
REV	DESCRIPTION	APPROVED
A	INITIAL RELEASE	1/22/2013
B	REVISION	1/27/2013

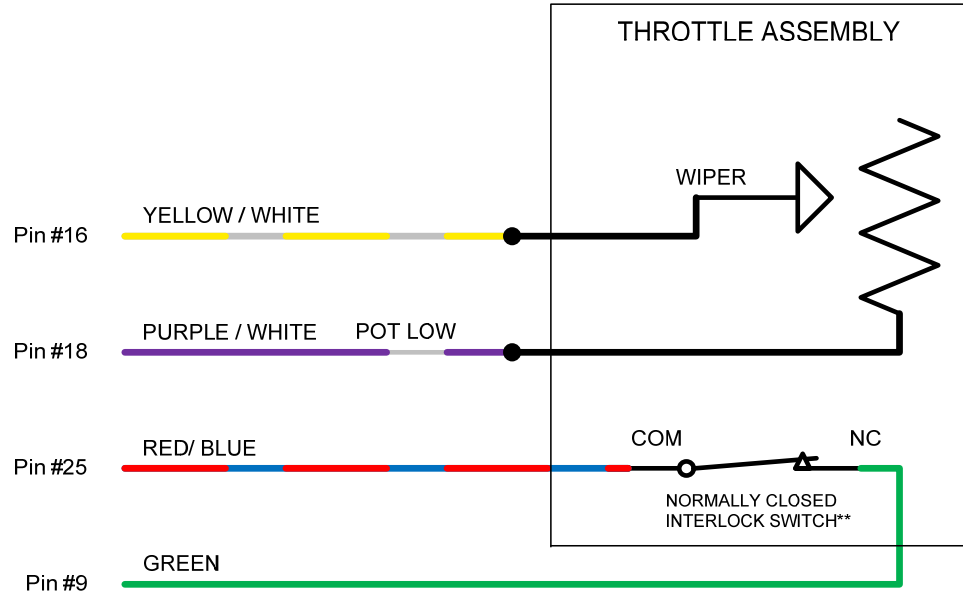

## TYPE 2 2 WIRE THROTTLE

\*\* When accelerator pedal IS PRESSED the interlock switch is released to its NORMAL position (switch not activated) thus completing the circuit since its green wire is connected to the normally closed (NC) connection.

CAD TYPE VISIO	APPLICABLE SOFTWARE
UNIT NONE	DRAWING 1010-THROTTLE-001
DRW SIZE A	TITLE
DATE 1/22/13	TYPE 2 2 WIRE THROTTLE
SUPPLIER PART	
SCALE NONE	SHEET 1 OF 8
REVISION	B
HPEVS	



**NOTICE:** This drawing is the property of Hi Performance Electric Vehicle Systems Inc., and/or its subsidiaries and affiliates (individually and collectively "HPEVS"), and contains highly proprietary, confidential, and trade secret information of HPEVS. The recipient of this drawing agrees (a) to use the information contained herein for the purpose for which it was furnished by HPEVS (b) to return this drawing upon HPEVS request. This notice shall appear on any complete or partial reproduction of this drawing.

REVISIONS		
REV	DESCRIPTION	APPROVED
A	INITIAL RELEASE	1/22/2013
B	REVISION	1/27/2013

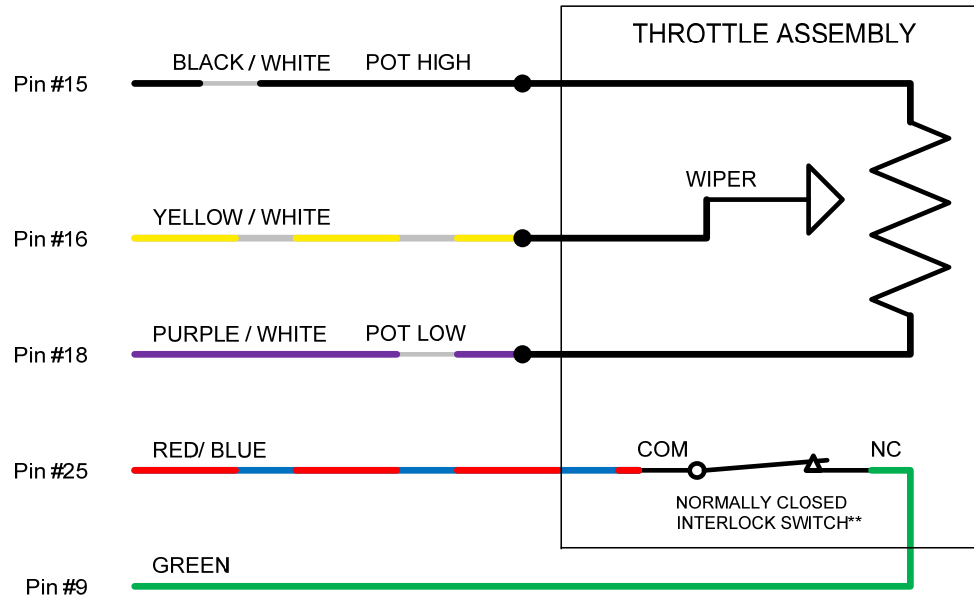

## TYPE 3 3 WIRE THROTTLE

\*\* When accelerator pedal IS PRESSED the interlock switch is released to its NORMAL position (switch not activated) thus completing the circuit since its green wire is connected to the normally closed (NC) connection.

CAD TYPE VISIO	APPLICABLE SOFTWARE
UNIT NONE	DRAWING 1010-THROTTLE-001
DRW SIZE A	TITLE
DATE 1/22/13	TYPE 3 3 WIRE THROTTLE
SUPPLIER PART	
SCALE NONE	SHEET 2 OF 8
REVISION	B
HPEVS	

**NOTICE:** This drawing is the property of Hi Performance Electric Vehicle Systems Inc., and/or its subsidiaries and affiliates (individually and collectively "HPEVS"), and contains highly proprietary, confidential, and trade secret information of HPEVS. The recipient of this drawing agrees (a) to use the information contained herein for the purpose for which it was furnished by HPEVS (b) to return this drawing upon HPEVS request. This notice shall appear on any complete or partial reproduction of this drawing.

REVISIONS		
REV	DESCRIPTION	APPROVED
A	INITIAL RELEASE	11/27/2013

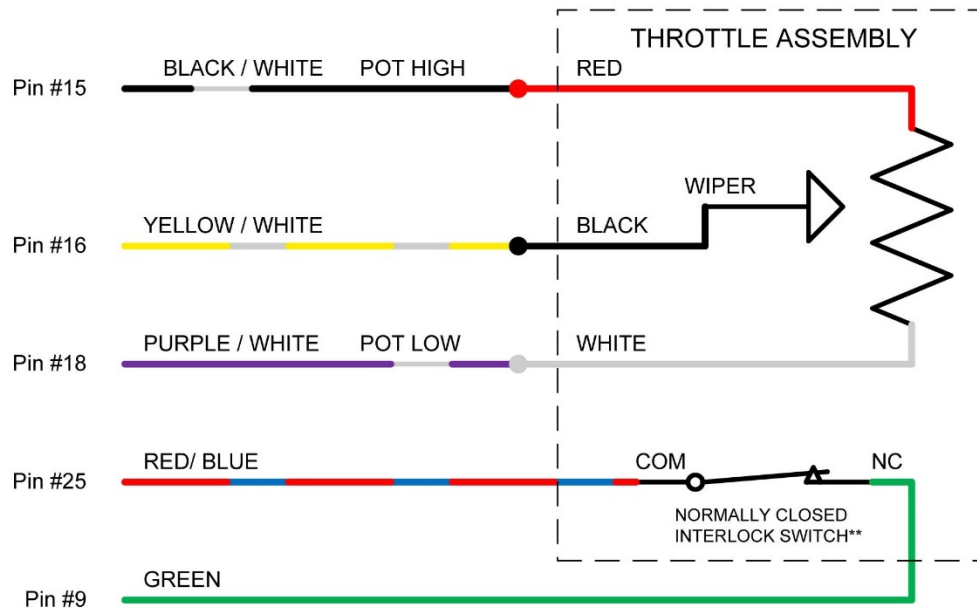

**CURTIS PB8  
THROTTLE  
ASSEMBLY**

\*\* When accelerator pedal IS PRESSED the interlock switch is released to its NORMAL position (switch not activated) thus completing the circuit since its green wire is connected to the normally closed (NC) connection.

CAD TYPE VISIO	APPLICABLE SOFTWARE		
UNIT NONE	DRAWING 1010-THROTTLE-001		
DRW SIZE A	TITLE CURTIS PB8 THROTTLE		
DATE 1/22/13			
SUPPLIER PART			
SCALE NONE	SHEET 3 OF 8	REVISION A	HPEVS

NOTICE: This drawing is the property of H Performance Electric Vehicle Systems, Inc., and/or its subsidiaries and affiliates (individually and collectively "HPEVS"), and contains highly proprietary, confidential, and trade secret information of HPEVS. The recipient of this drawing agrees (a) to use the information contained herein for the purpose for which it was furnished by HPEVS (b) to return this drawing upon HPEVS request. This notice shall appear on any complete or partial reproduction of this drawing.

REVISIONS		
REV	DESCRIPTION	APPROVED
A	Initial Release	11/17/2015

### CURTIS ELECTRONIC THROTTLE MODEL NUMBERS ET-126 OR ET-134 TYPE 3

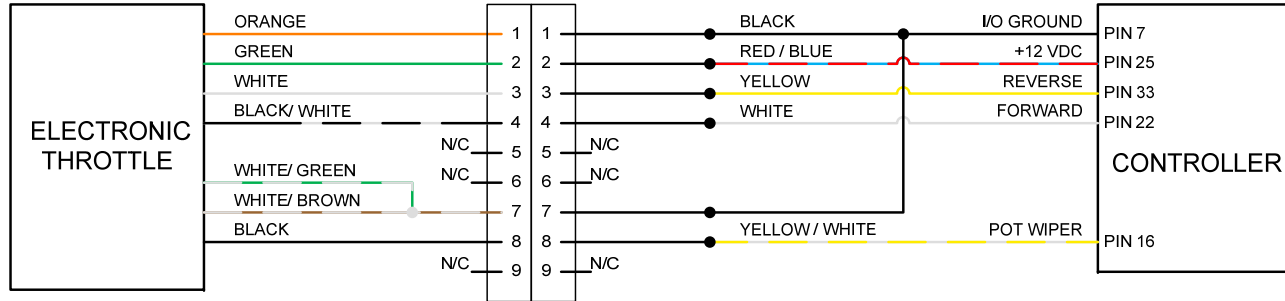

ET-126 HAS A SPRING RETURN SO THAT THE THROTTLE RETURNS TO NEUTRAL POSITION

ET-134 DOES NOT HAVE A SPRING RETURN

CAD TYPE	APPLICABLE SOFTWARE	VER 2.5
VISIO	DRAWING	1010-ETHrottle
UNIT NONE		
DRW SIZE A	TITLE Curtis Electronic Throttle	
DATE 11/17/15	Part ET-126 OR ET-134 Type 3	
SUPPLIER PART		
SCALE none	SHEET 1 OF 1	REVISION A HPEVS

**NOTICE:** This drawing is the property of Hi Performance Electric Vehicle Systems Inc., and/or its subsidiaries and affiliates (individually and collectively "HPEVS"), and contains highly proprietary, confidential, and trade secret information of HPEVS. The recipient of this drawing agrees (a) to use the information contained herein for the purpose for which it was furnished by HPEVS (b) to return this drawing upon HPEVS request. This notice shall appear on any complete or partial reproduction of this drawing.

REVISIONS		
REV	DESCRIPTION	APPROVED
A	INITIAL RELEASE	2/3/2015

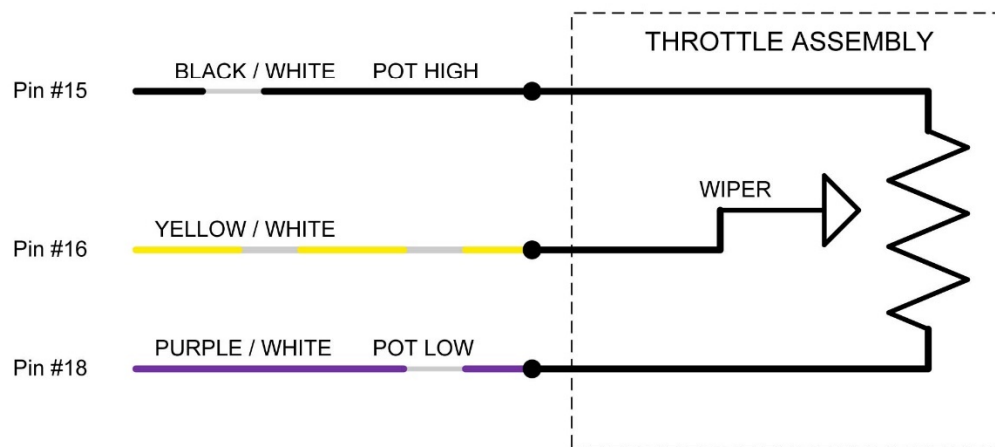

**3 WIRE WIG WAG  
TYPE 4  
THROTTLE\*\***

\*\* No Forward or Reverse input used. No Interlock Switch used.

CAD TYPE VISIO	APPLICABLE SOFTWARE		
UNIT NONE	DRAWING	1010-THROTTLE-001	
DRW SIZE A	TITLE 3 WIRE TYPE 4 WIG WAG		
DATE 2/3/15			
SUPPLIER PART			
SCALE NONE	SHEET 8 OF 8	REVISION A	HPEVS

## THROTTLE INTERLOCK CONNECTION

The throttle interlock connection is required for both 2 and 3 wire throttle pot assemblies. The Green wire is connected to the Normally Closed tab. The red/blue wire is connected to the common tab. See picture below.

NOTE: when the throttle IS ENGAGED the interlock switch is released to its NORMAL position (switch not activated) thus completing the circuit since its green wire is connected to the normally closed (NC) connection.

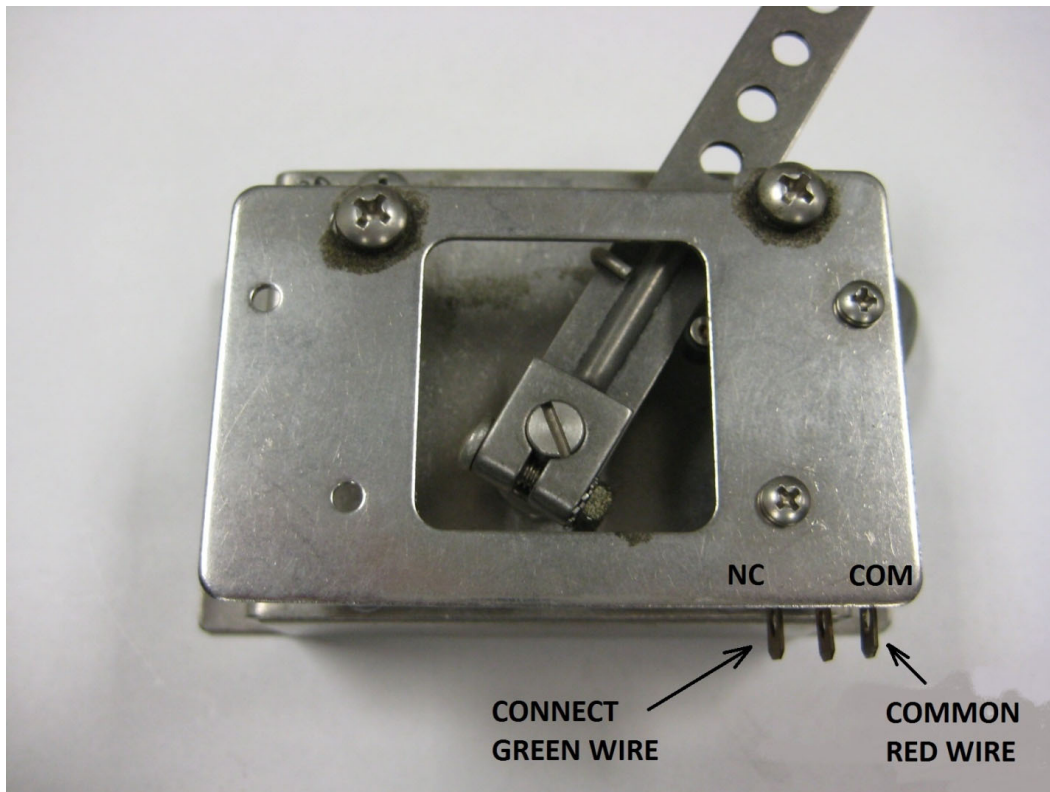

## BRAKE INPUT CONFIGURATION

Depending on the type of brake input used for the application, the different types of brake input configurations are listed in the table below. Electrical schematics are also included within the following pages.

<b>BRAKE INPUT CONFIGURATION</b>	<b>TYPE</b>
NO BRAKE POT INSTALLED	TYPE 0
PRESSURE TRANSDUCER/ ELECTRONIC 0-5V INPUT or 3-WIRE POT	TYPE 1
2 WIRE 0-5k $\Omega$ POT	TYPE 2
SWITCH	TYPE 3

**NOTICE:** This drawing is the property of Hi Performance Electric Vehicle Systems Inc., and/or its subsidiaries and affiliates (individually and collectively "HPEVS"), and contains highly proprietary, confidential, and trade secret information of HPEVS. The recipient of this drawing agrees (a) to use the information contained herein for the purpose for which it was furnished by HPEVS (b) to return this drawing upon HPEVS request. This notice shall appear on any complete or partial reproduction of this drawing.

REVISIONS		
REV	DESCRIPTION	APPROVED
A	INITIAL RELEASE	2/19/2013

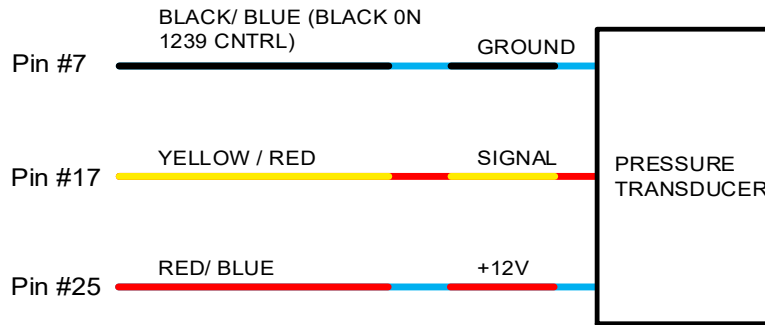

## TYPE 1 PRESSURE TRANSDUCER

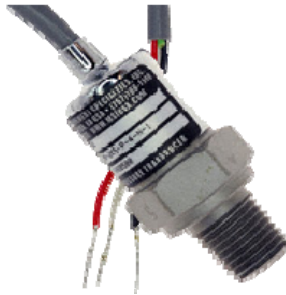

**\*\* Typical Pressure Transducer Ratings**  
 8-30 Volt Input  
 1-5 Volt Output  
 2500 PSI

**Website Link:** [www.digikey.com](http://www.digikey.com)  
**Part Number:** M3041-000005-2K5PG-ND  
**Manufacturer Part #:** M3041-000005-2K5PG

CAD TYPE VISIO	CAD LOC.	CAD FILE	DRW SIZE A
OPER. NO.	UNIT	DRAWING 1010-BRAKE	
DESIGN	DETAIL	TITLE	
CHECKED	SAFETY	PRESSURE TRANSDUCER	
SCALE NONE	DATE 2/19/13	REVISION A SHEET 2 OF 2	<b>HPEVS</b>

**NOTICE:** This drawing is the property of Hi Performance Electric Vehicle Systems Inc., and/or its subsidiaries and affiliates (individually and collectively "HPEVS"), and contains highly proprietary, confidential, and trade secret information of HPEVS. The recipient of this drawing agrees (a) to use the information contained herein for the purpose for which it was furnished by HPEVS (b) to return this drawing upon HPEVS request. This notice shall appear on any complete or partial reproduction of this drawing.

REVISIONS		
REV	DESCRIPTION	APPROVED
A	INITIAL RELEASE	2/19/2013

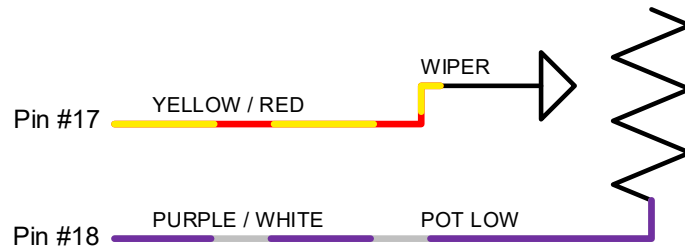

**TYPE 2  
2 WIRE BRAKE POT**

CAD TYPE VISIO	CAD LOC.	CAD FILE	DRW SIZE A
OPER. NO.	UNIT	DRAWING 1010-BRAKE	
DESIGN	DETAIL	TITLE <b>2 WIRE BRAKE POT</b>	
CHECKED	SAFETY		
SCALE NONE	DATE 2/19/13	REVISION A	<b>HPEVS</b>
		SHEET 1 OF 1	



## OPTIONAL ACTIVE BRAKE LIGHT CONFIGURATIONS

These optional brake light configurations are used to activate the brake lights during regenerative braking or when the vehicle brakes are applied. Based on the brake type configuration that is being utilized in the application, use one of the following wiring configurations.

**NOTICE:** This drawing is the property of Hi Performance Electric Vehicle Systems Inc., and/or its subsidiaries and affiliates (individually and collectively "HPEVS"), and contains highly proprietary, confidential, and trade secret information of HPEVS. The recipient of this drawing agrees (a) to use the information contained herein for the purpose for which it was furnished by HPEVS (b) to return this drawing upon HPEVS request. This notice shall appear on any complete or partial reproduction of this drawing.

REVISIONS		
REV	DESCRIPTION	APPROVED
A	INITIAL RELEASE	2/19/2013

### ACTIVE BRAKE LIGHT CONFIGURATION FOR ALL BRAKE TYPES (1-3) 1232-1234-1236-1238 "E" AND "SE" CONTROLLERS

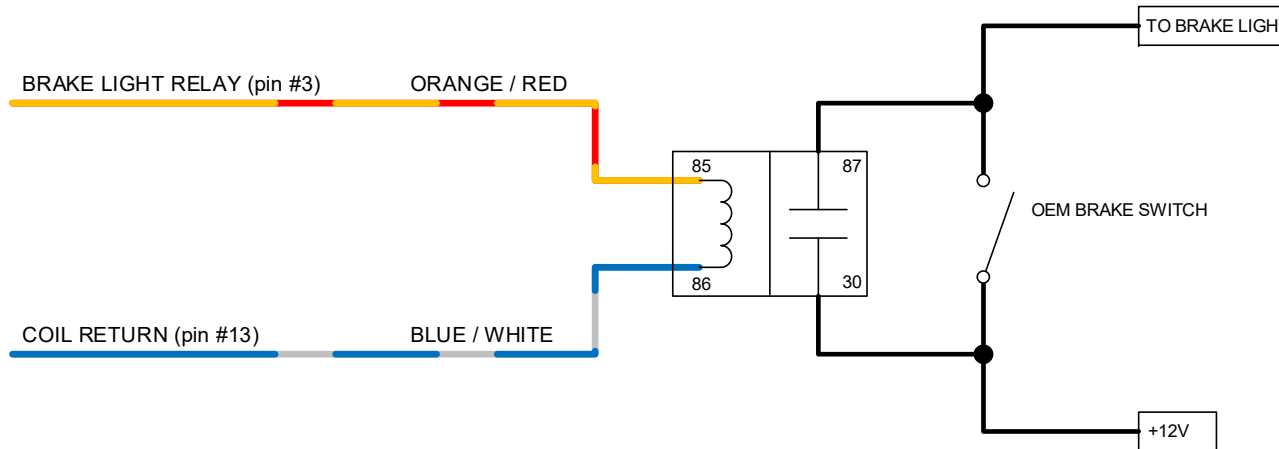

\*\* This option turns the brake lights ON during REGEN. Brake TYPE 3 allows for NEUTRAL BRAKING AND/OR BOOSTED REGEN while pressing the brake pedal. Brake TYPE 1 & 2 uses a variable input for BOOSTED REGEN. Brake TYPE 0 does not allow for BOOSTED BRAKE while pressing the brake pedal.

CAD TYPE VISIO	CAD LOC.	CAD FILE	DRW SIZE A
OPER. NO.	UNIT	DRAWING 1010-BRAKE	
DESIGN	DETAIL	TITLE	
CHECKED	SAFETY	OPTION 1 BRAKE SWITCH INPUT	
SCALE NONE	DATE 12/5/13	REVISION A	<b>HPEVS</b>
		SHEET 3 OF 4	

**NOTICE:** This drawing is the property of Hi Performance Electric Vehicle Systems Inc., and/or its subsidiaries and affiliates (individually and collectively "HPEVS"), and contains highly proprietary, confidential, and trade secret information of HPEVS. The recipient of this drawing agrees (a) to use the information contained herein for the purpose for which it was furnished by HPEVS (b) to return this drawing upon HPEVS request. This notice shall appear on any complete or partial reproduction of this drawing.

REVISIONS		
REV	DESCRIPTION	APPROVED
A	INITIAL RELEASE	2/19/2013

**OPTION 1  
FOR BRAKE TYPE 3 CONFIGURATION  
1232-1234-1236-1238 "E" AND "SE" CONTROLLERS**

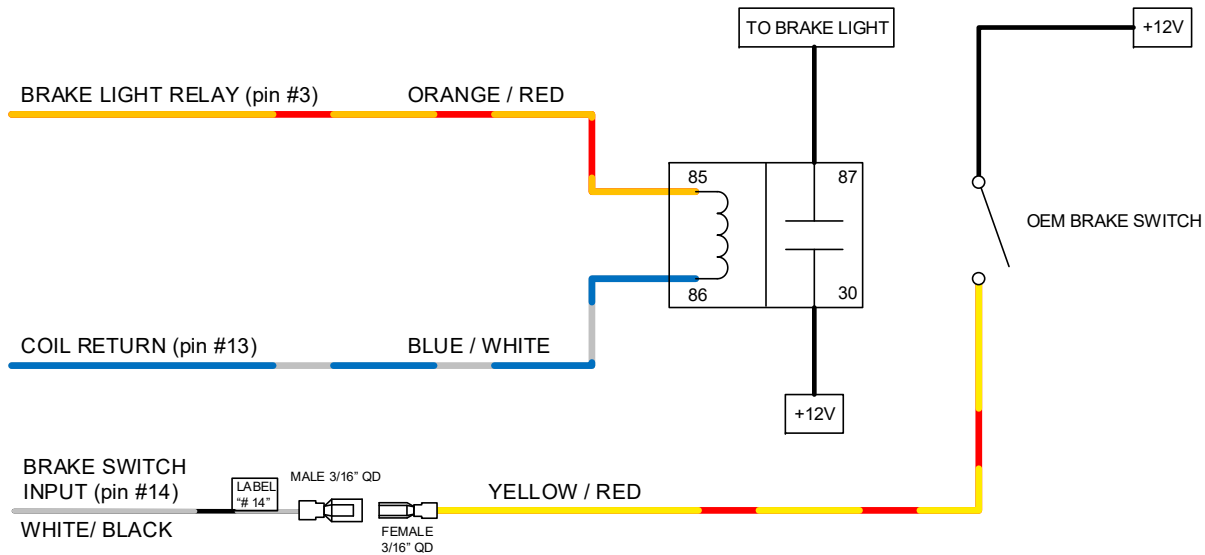

**\*\* This option will turn ON the brake lights when either of two conditions are satisfied:**

1. No throttle input. If neutral braking or boosted regen is active.
2. Pressure to the brake pedal is applied and the OEM brake switch is active.

CAD TYPE VISIO	CAD LOC.	CAD FILE	DRW SIZE A
OPER. NO.	UNIT	DRAWING 1010-BRAKE	
DESIGN	DETAIL	TITLE	OPTION 2
CHECKED	SAFETY	BRAKE SWITCH INPUT 1232-1234-1236-1238 "E" AND "SE" CONTROLLERS	
SCALE NONE	DATE 12/5/13	REVISION A	<b>HPEVS</b>
		SHEET 3 OF 4	

**NOTICE:** This drawing is the property of Hi Performance Electric Vehicle Systems Inc., and/or its subsidiaries and affiliates (individually and collectively "HPEVS"), and contains highly proprietary, confidential, and trade secret information of HPEVS. The recipient of this drawing agrees (a) to use the information contained herein for the purpose for which it was furnished by HPEVS (b) to return this drawing upon HPEVS request. This notice shall appear on any complete or partial reproduction of this drawing.

REVISIONS		
REV	DESCRIPTION	APPROVED
A	INITIAL RELEASE	2/19/2013

**OPTION 2  
FOR BRAKE TYPE 3 CONFIGURATION  
1232-1234-1236-1238 "E" AND "SE" CONTROLLERS**

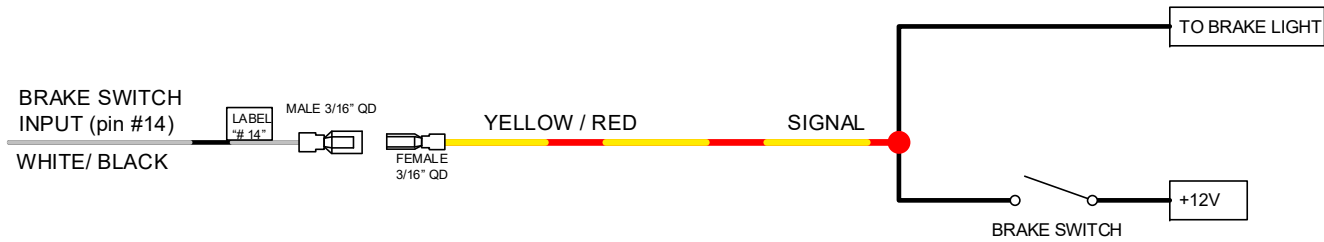

- \*\* This option will provide single level BOOSTED REGEN when brake pedal pressure is applied.
- \*\* Brake lights will not turn on during REGEN.

CAD TYPE VISIO	CAD LOC.	CAD FILE	DRW SIZE A
OPER. NO.	UNIT	DRAWING 1010-BRAKE	
DESIGN	DETAIL	TITLE	
CHECKED	SAFETY	OPTION 3 BRAKE SWITCH INPUT 1232-1234-1236-1238 "E" AND "SE" CONTROLLERS	
SCALE NONE	DATE 2/19/13	REVISION A	<b>HPEVS</b>
		SHEET 4 OF 4	

**NOTICE:** This drawing is the property of Hi Performance Electric Vehicle Systems Inc., and/or its subsidiaries and affiliates (individually and collectively "HPEVS"), and contains highly proprietary, confidential, and trade secret information of HPEVS. The recipient of this drawing agrees (a) to use the information contained herein for the purpose for which it was furnished by HPEVS (b) to return this drawing upon HPEVS request. This notice shall appear on any complete or partial reproduction of this drawing.

REVISIONS		
REV	DESCRIPTION	APPROVED
A	INITIAL RELEASE	3/11/2013
B	Revision for clarification	10/30/2013

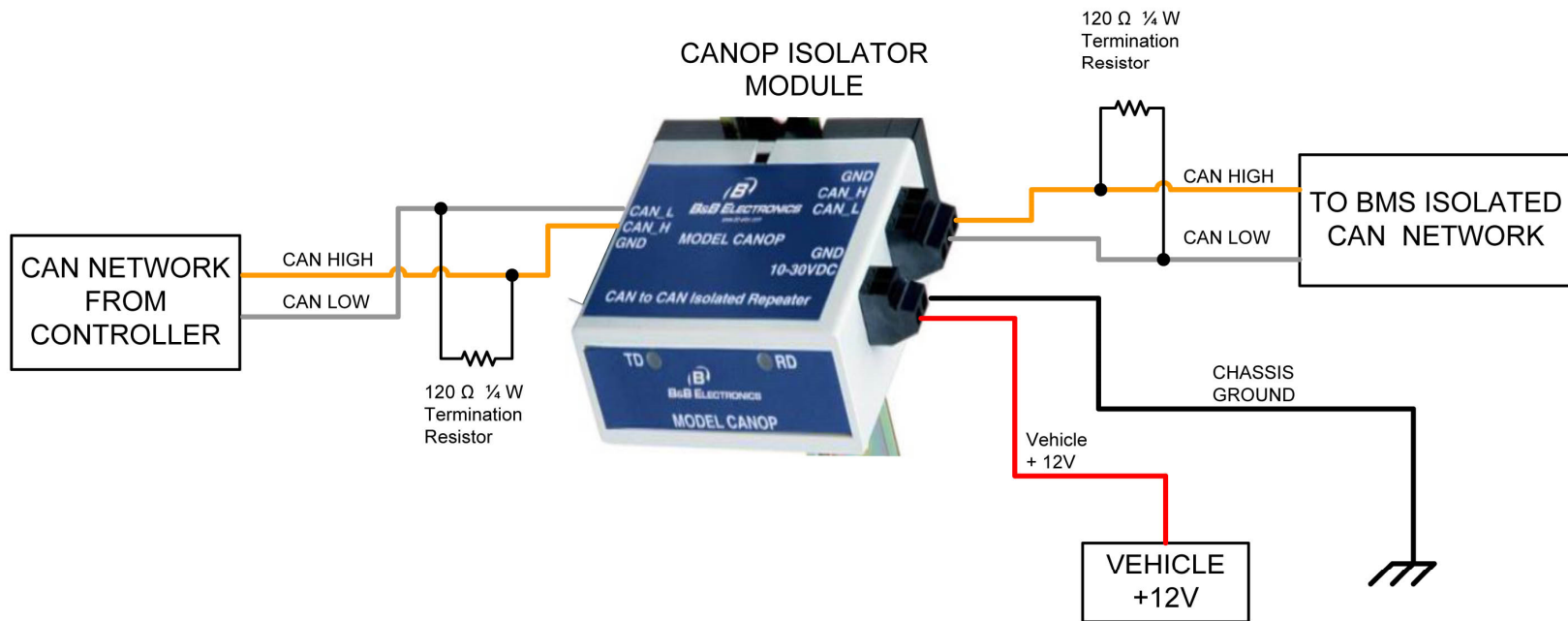

CAD TYPE VISIO	CAD LOC.	CAD FILE	DRW SIZE A
OPER. NO.	UNIT	DRAWING 1010-CAN-OP-ISOLATOR	
DESIGN	DETAIL	TITLE	
CHECKED	SAFETY	CAN ISOLATOR	
SCALE NONE	DATE 4/17/13	REVISION B	<b>HPEVS</b>
		SHEET 1 OF 1	

**NOTICE:** This drawing is the property of Hi Performance Electric Vehicle Systems Inc., and/or its subsidiaries and affiliates (individually and collectively "HPEVS"), and contains highly proprietary, confidential, and trade secret information of HPEVS. The recipient of this drawing agrees (a) to use the information contained herein for the purpose for which it was furnished by HPEVS (b) to return this drawing upon HPEVS request. This notice shall appear on any complete or partial reproduction of this drawing.

REVISIONS		
REV	DESCRIPTION	APPROVED
A	INITIAL RELEASE	3/11/2013
B	Revision for clarification	10/30/2013

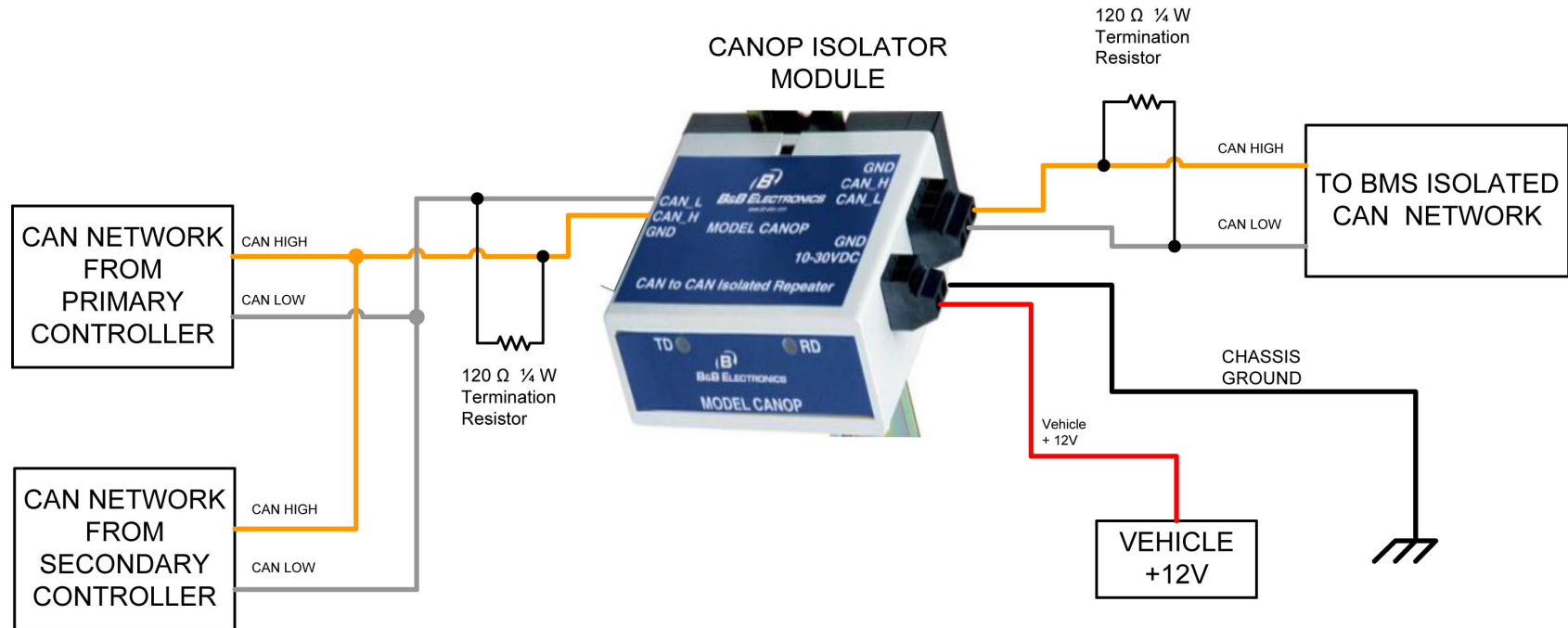

CAD TYPE VISIO	CAD LOC.	CAD FILE	DRW SIZE A
OPER. NO.	UNIT	DRAWING 1010-CAN-OP-ISOLATOR	
DESIGN	DETAIL	TITLE	
CHECKED	SAFETY	CAN ISOLATOR DUAL 1238 CONTROLLER	
SCALE NONE	DATE 4/17/13	REVISION B	<b>HPEVS</b>
		SHEET 1 OF 1	

**NOTICE:** This drawing is the property of Hi Performance Electric Vehicle Systems Inc., and/or its subsidiaries and affiliates (individually and collectively "HPEVS"), and contains highly proprietary, confidential, and trade secret information of HPEVS. The recipient of this drawing agrees (a) to use the information contained herein for the purpose for which it was furnished by HPEVS (b) to return this drawing upon HPEVS request. This notice shall appear on any complete or partial reproduction of this drawing.

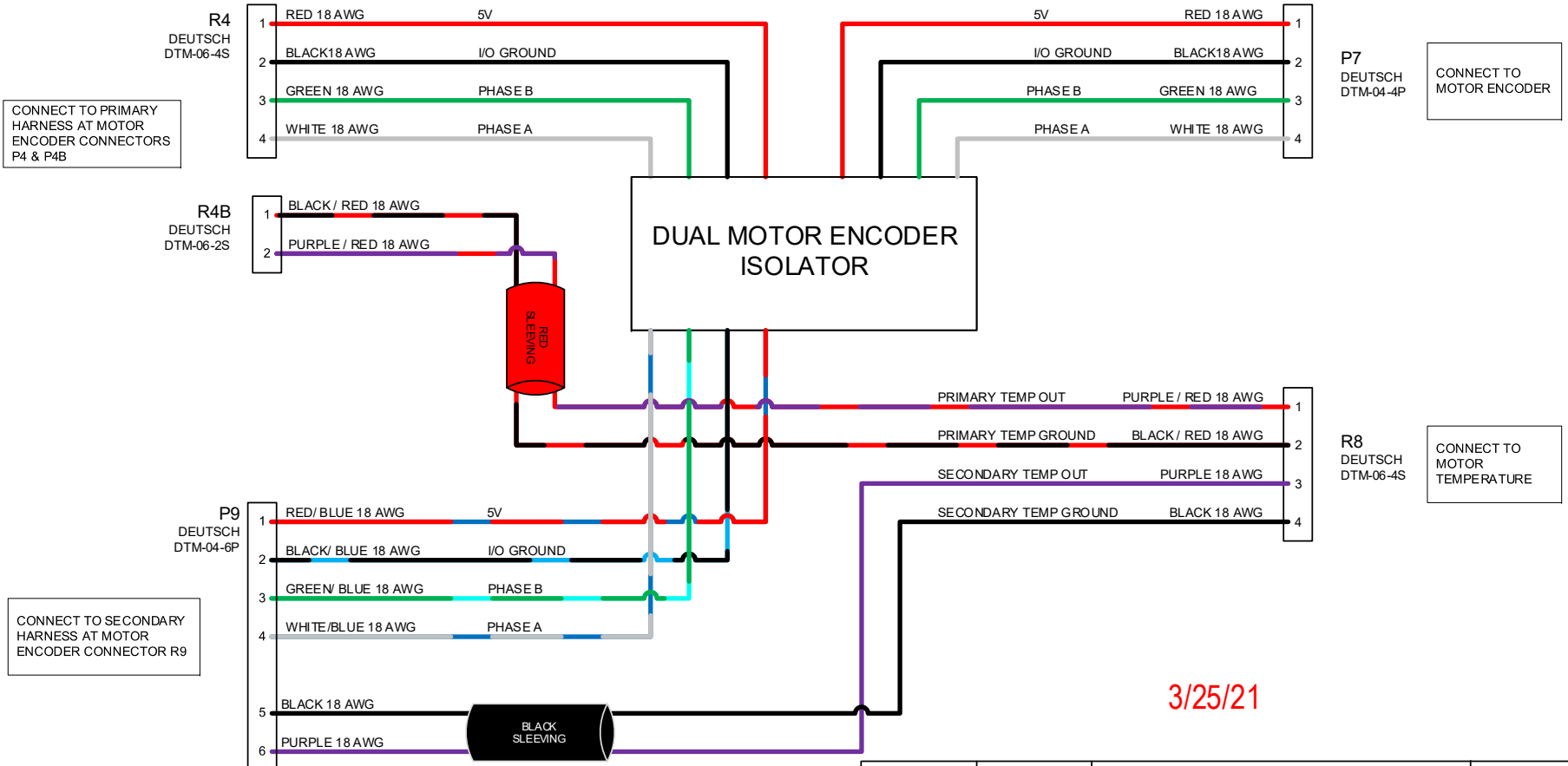

CONNECT TO PRIMARY HARNESS AT MOTOR ENCODER CONNECTORS P4 & P4B

CONNECT TO SECONDARY HARNESS AT MOTOR ENCODER CONNECTOR R9

CONNECT TO MOTOR ENCODER

CONNECT TO MOTOR TEMPERATURE

CAD TYPE VISIO	CAD LOC.	APPLICABLE SOFTWARE	DRW SIZE B
OPER. NO.	UNIT	DRAWING 1010-TWIN-ENCODER-ISOLATOR	
DESIGN	DETAIL	TITLE	
CHECKED	SAFETY	DUAL MOTOR ENCODER ISOLATOR SCHEMATICS	
SCALE NONE	DATE 3/25/21	REVISION D	HPEVS
		SHEET 1 OF 1	

Program Entries Generic 532 (Parameters)							
Level 1	Parameter	Level 2	Parameter	Units	Parameter Range	Default Setting	Notes
<b>User Settings</b>							
		<b>Speed Settings</b>					
			Forward Speed	RPM	200 to 8500	6500	Defines the maximum requested motor rpm at full throttle with forward selected.
			Reverse Speed	RPM	200 to 8500	6500	Defines the maximum requested motor rpm at full throttle with reverse selected.
			Econo Speed	RPM	200 to 8500	6500	Defines the maximum requested motor rpm at full throttle with econo mode on.
		<b>Accel Rates</b>					
			Normal Accel Rate	Seconds	0.1 to 5.0	0.4	Sets the rate (in seconds) at which the speed command increases when throttle is applied. Larger values represent slower response.
			Econo Accel Rate	Seconds	0.1 to 5.0	0.5	Sets the rate (in seconds) at which the speed command increases in econo mode when throttle is applied. Larger values represent slower response.
		<b>Throttle Settings</b>					
			Throttle Type	N/A	1 to 4	3	The Curtis controllers accept a variety of throttle inputs. The throttle type parameter can be programmed as follows: 1= Electronic throttle (NO switch, 0-5 volt). 2: 2-wire rheostat, 0-5kΩ input 3: single-ended 3-wire 0-5kΩ potentiometer, or 0-5V voltage source or Electronic (Default) 4: wigwag 3-wire 0-5kΩ potentiometer, or 0-5V voltage source <a href="#">CLICK HERE TO SEE ADDITIONAL NOTES</a> <b>Note: Do not change this parameter while the controller is powering the motor. Any time this parameter is changed a Parameter Change Fault (fault code 49) is set and must be cleared by cycling power; this protects the controller and the operator.</b>
			Deadband	Volt	0.00 to 5.00	.30	Defines the wiper voltage at the throttle deadband threshold. Increasing the throttle deadband setting will increase the neutral range.
			Throttle Max	Volt	0.00 to 5.00	3.5	Defines the wiper voltage required to produce 100% controller output. Decreasing the throttle max setting reduces the wiper voltage and therefore the full stroke necessary to produce full controller output.
			Mapped Throttle	%	0 to 100	50	Modifies the vehicle's response to the throttle input. Setting the throttle map at 50% provides a linear output response to throttle position. Values below 50% reduce the controller output at low throttle settings, providing enhanced slow speed maneuverability. Values above 50% give the vehicle a faster, more responsive feel at low throttle settings.
		<b>Brake Pedal Settings</b>					
			Brake Type		0 to 3	0	Select the brake type that is being utilized for the application being installed. The selection availability is as follows: a) Type 0= No Brake input used (Default) b) Type 1= 3-wire pot or an electronic (includes transducer or hall sensor.) c) Type 2= 2 wire 0 to 5k pot. d) Type 3= Switch
			Brake Deadband	Volt	0.00 to 5.00	0.30	Defines the wiper voltage at the brake deadband threshold. Increasing the brake deadband setting will increase the neutral range.
			Brake Max	Volt	0.00 to 5.00	3.50	Defines the wiper voltage required to produce 100% controller output. Decreasing the brake max setting reduces the wiper voltage and therefore the full stroke necessary to produce full controller output.
			Regen Brake Light Threshold	AMP	0 to 400	50	Allows for turning on the brake lamp based on the amount of regenerative braking that is taking place when off of the throttle. A higher number to this parameter means that there has to be a high amount of regen to be taking place to turn on the brake lamp
		<b>Current Limits</b>					
			Normal Neutral Braking	%	0 to 100	15	This parameter will allow for adjustment to Neutral Braking.
			Econo Neutral Braking	%	0 to 100	25	This parameter will allow for adjustment to Neutral Braking in economy mode.
			Shift Neutral Braking	%	0 to 100	7	Adjustment to neutral braking while pressing the clutch to shift a manual transmission
			Normal Drive Current Limit	%	5 to 100	100	Normal Drive Current Limit sets the maximum RMS current the controller will supply to the motor during drive operation, as a percentage of the controller's full rated current in normal operating mode. Reducing this value will reduce the maximum drive torque.
			Econo Drive Current Limit	%	5 to 100	60	Sets the maximum RMS current the controller will supply to the motor during drive operation, as a percentage of the controller's full rated current in economy operating mode. Reducing this value will reduce the maximum drive torque.
			Brake Current Limit	%	5 to 100	10	Sets the maximum RMS regen current during braking when a brake command is given, as a percentage of the controller's full rated current. Typically the brake current limit is set equal to the regen current limit. The brake current limit overrides the regen current limit when the brake input is active.



Level 1	Parameter	Level 2	Parameter	Units	Parameter Range	Default Setting	Notes
		<b>Idle Setup</b>					
			Idle Enable		On/Off	Off	on = motor idle will be turned on
			Clutch Start Enable		On/Off	Off	Enables clutch switch so that clutch needs to be depressed to start vehicle
			Idle Speed	RPM	300 to 1000	600	motor idle speed
			Idle Torque	%	0 to 100	50	percentage of available torque at idle speed
			Creep Torque	%	0 to 100	0	Creep torque available when Idle is set to OFF. Allows for the amount of torque applied when the vehicle when at a stop and no throttle input
		<b>Motor Tuning</b>					
			Motor Type		9 to 77	Based on motor type	Input motor type
			Base Speed	RPM	200 to 6000	3500	The speed set point for which the motor goes into field weakening.
			Field Weakening	%	0 to 100	50	Determines the amount of high speed power the controller will allow, while still maintaining maximum efficiency at the allowed power. Reducing this parameter effectively reduces controller current at high speeds, which can reduce energy consumption and motor heating, but at the expense of reduced available torque from the motor.
			Econo Field Weakening	%	0 to 100	0	Determines the amount of high speed power the controller will allow while in econo mode, while still maintaining maximum efficiency at the allowed power. Reducing this parameter effectively reduces controller current at high speeds, which can reduce energy consumption and motor heating, but at the expense of reduced available torque from the motor.
			Weakening Rate	%	0 to 100	36	Determines the control loop gains for field weakening. Setting the rate too low may create surging in the vehicle as it accelerates at mid to high speeds. Setting the rate too high may create high frequency oscillations (usually audible) when the vehicle accelerates at mid to high speeds.
		<b>Main Contactor</b>					
			Main Contactor Voltage	Volt	12 to 96	24	Main contactor voltage that is used in the system
			Main Holding %	%	0 to 100	80	The main contactor holding voltage parameter allows a reduced average voltage to be applied to the contactor coil once it has closed. This parameter must be set high enough to hold the contactor closed
		<b>Display Menu Items</b>					
			Auto Scroll	N/A	On/Off	Off	Turn on auto scroll function on 840 display to show monitored items listed below
			Scroll Delay Time	Seconds	1 to 10	4	Time that delays scroll function displaying the menu items below on the Spyglass 840
			Display SOC	N/A	On/Off	Off	When turned on the State Of Charge (SOC) of battery pack will be displayed. Acuity required.
			Display Motor RPM	N/A	On/Off	On	When turned on the Motor RPM will be displayed
			Display Battery Amps	N/A	On/Off	On	When turned on, battery pack current will be displayed
			Display Voltage	N/A	On/Off	On	When turned on, battery pack voltage will be displayed
			Display Motor Temp	N/A	On/Off	On	When turned on, motor temperature will be displayed
			Display Controller Temp	N/A	On/Off	On	When turned on, controller temperature will be displayed
			Display Minimum Voltage	N/A	On/Off	On	When turned on, minimum voltage during operation will be displayed
			Display Maximum Current	N/A	On/Off	On	When turned on, maximum current during operation will be displayed
		<b>BMS</b>					
			BMS Installed		On/Off	Off	When on can be used with Orion BMS. BMS must have CAN messages configured.
			BMS Address		768 to 1536	768	BMS Address range in decimal. Hex range = 0x300 to 0x600
			User Undervoltage	%	50 to 90	80	The value of this parameter is a percentage of the Nominal Voltage setting. The User Undervoltage parameter can be used to adjust the undervoltage threshold, which is the voltage at which the controller will cut back drive current to prevent damage to the electrical system.
			Low Cell Begin Cutback	Volt	0.000 to 4.000	2.800	Low cell cutback begin sets the voltage of the lowest cell where current limiting will begin
			Low Cell Full Cutback	Volt	0.000 to 4.000	2.300	Low Cell Full Cutback parameter sets the voltage of the lowest cell where full current limiting is in force
			Max Current at Full Cutback	%	0 to 100	50	Maximum Current Full Cutback parameter sets the maximum current allowed when low voltage full cutback is in force
			Maximum Cell Voltage	Volt	2.000 to 4.000	3.700	Maximum cell voltage parameter sets the voltage at which regen is turned off to prevent overcharging
			Low SOC Cutback	%	0 to 100	20	Low SOC (State of Charge) Cutback parameter sets the SOC at which current limiting is in force
			Max Current at Low SOC	%	0 to 100	30	Maximum Current Low SOC (State of Charge) parameter sets the maximum current allowed when SOC is lower than Low SOC Cutback

Level 1	Parameter	Level 2	Parameter	Units	Parameter Range	Default Setting	Notes
		Dual Drive					
			Dual Drive Mode		On/Off	Based on using either single motor or dual motor	This parameter turns dual drive off or on. Turn on for a dual motor.
			Response Timeout	ms	50 to 1000	200	Time allotted for the secondary controller(s) to respond to the primary controller
		Misc					
			Max Output Frequency	Hz	0 to 4000	266	Tachometer frequency allows the user to set-up the vehicles tachometer to work correctly based on the number of cylinders the original internal combustion engine had that was removed from the vehicle
			Prg Mode Step Timer	Seconds	1.0 to 10.0	4.0	The time in seconds that the program steps through program mode.
			Generic CAN Message ID Dec		1537 to 1616	1537	CAN ID that the controller transmits. Hex range = 0x601 to 0x650
		Software Version					
			VCL Version		0 to 32767	Based on VCL software version	Software Version
			OS Version		0 to 32767	Based on Operating system installed	Version number of the operating system software that is loaded into the controller. This variable specifies the major version number of the controller's operating system.
			OS Build Number		0 to 32767	Based on software OS Build system	Build number of the operating system software that is loaded into the controller.

# ADDITIONAL NOTES

## Setup for Type 4 WigWag Throttle

1: Using a handheld Programmer or the 1314 Programming Station, Go to "Monitor", then "Inputs" and note at the Throttle Pot Voltage reading with the throttle in the neutral, full forward and full reverse positions. If the Throttle voltage is lower in the forward direction than in the reverse direction, swap the outer two legs of the throttle pot.

2: Set the Forward Deadband parameter to .1 volts higher than the value noted.

3: Set the Reverse Deadband parameter to .1 volt less than the value noted.

4: Set the Forward Max parameter to .1 volt less than the full forward throttle voltage noted.

5: Set the Reverse Max parameter to .1 volt higher than the full reverse voltage noted.

Generic 532 Software Monitor Items

Level 1	Parameter	Level 2	Parameter	Units	Parameter Range	Notes
<b>Dual Drive</b>						
	Dual Drive State				On/Off	On = A secondary controller has been detected in a dual drive system
<b>CAN Communication</b>						
	BMS Communicating				On/Off	On = BMS is communicating to the controller through the CAN Bus
	Charger Communicating				On/Off	On = Charger is communicating to the controller through the CAN Bus
<b>Battery Information</b>						
		<b>Peak I&amp;E</b>				
			Peak RMS Current	AMP	0 to 1000	Peak RMS current reported while the system is under load
			Minimum Voltage	Volt	0 to 170.0	Minimum voltage reported while the system is under load
		<b>General</b>				
			Keyswitch Voltage	Volt	0 to 150	Voltage at KSI (Pin 1)
			Measured Current	AMP	-600 to 600	The Measured System Current During Operation
			Remaining Amphours	AMP	0 to 500	Remaining Battery Amphours
			BDI Percentage	%	0 to 100	Battery state of charge.
			Aux Battery Voltage	Volt	0 to 20	Auxiliary battery voltage
		<b>Charging Info</b>				
			Charger Output Current	Ampere	0 to 100	Battery charger output current to the battery pack
			Charger Output Voltage	Volt	0 to 1400	Battery charger output voltage to the battery pack
			Charger Status	N/A	0 to 32	Status of the charger.
		<b>Cell Monitor</b>				
			Highest Cell			Identification of the battery with the highest voltage
			Highest Cells Voltage	Volt	0 to 4.500	Highest battery cell voltage
			Lowest Cell			Identification of the battery with the lowest voltage
			Lowest Cells Voltage	Volt	0 to 4.500	lowest battery cell voltage
			Highest Temperature	°C		Highest battery temperature within the battery pack
			Lowest Temperature	°C		Lowest battery temperature within the battery pack

# ORION BATTERY MANAGEMENT SYSTEM (BMS)

The Orion BMS is a full featured lithium ion battery management system that is specifically designed to meet the tough requirements of protecting and managing battery packs for electric vehicles. We have incorporated the Orion BMS into our software packages and strongly suggest using their BMS to protect your investment.

**Wiring Diagram:** The wiring diagrams for both the Orion BMS and Orion BMS Jr. can be found at <http://www.orionbms.com/resources/>.

This product is designed to be integrated into an application. Integration must be performed by a qualified person trained in electrical engineering and familiar with the characteristics and safety requirements of lithium batteries. Proper integration, selection of components, wire selection, installation, routing of cables and interconnects, and the determination of the suitability of this product for the application are fully the responsibility of the integrator.

Considerations for wiring:

- 1) The **voltage tap connectors must be DISCONNECTED from the BMS when being wired or when wiring is being modified for personal safety and to prevent damage.** Wiring while connected to the BMS may pose a personal safety hazard and/or fire risk since the remaining wires within the cell group can become electrically 'hot' due to internal protection diodes. Additionally, wiring with the BMS connected significantly increases the risk of damage to the BMS. Damage to the BMS from mis-wiring or misuse is not covered under warranty. **Immediately disconnect the BMS from the battery if the BMS is damaged.**
- 2) **The BMS must have a means of controlling and shutting off any connected charger, load, source or any other means of charge and discharge. Two shutoff mechanisms should be present to turn off a charger.** The charge safety signal is designed to be used as an emergency backup if a digital CAN control or digital charge enable signal fails. If the charger does not support an analog shutoff, an AC relay can be used in series with the charger power supply. This is the last line of defense if a failure occurs and should not be omitted. **In addition** to the above safety, the battery charger should be programmed such that it does not exceed the maximum pack voltage if a failure occurs.
- 3) All battery packs must be protected from over-current with a suitable current limiting device such as a fuse. If a fuse or safety disconnect is positioned between the first and last cell of a battery pack, it must be wired in certain locations. Read Safety Disconnects and Fuse Position for more information. **Failure to comply may result in catastrophic failure of the BMS from full stack potential present across two adjacent cell taps if a fuse blows or if the safety disconnect is removed and will not provide the required safety isolation. Read the full wiring manual before wiring the BMS, especially the cell tap harnesses.**
- 4) Always **verify voltage taps are wired correctly** before plugging them into the Orion BMS. Failure to do so may result in damage to the BMS. Damage to the BMS from mis-wiring or misuse is not covered under warranty and some incorrect wiring may pose a personal safety risk or fire risk from energy from the battery pack. Please see

the section “Verifying the wiring” for methods of testing to ensure the voltage taps are wired properly. Immediately disconnect the Orion BMS from cells if it is incorrectly wired. Leaving the Orion BMS connected to cells when incorrectly wired may drain incorrectly wired cells, even when the unit is turned off which may permanently damage connected cells.

5) Make sure that all cells are connected to the BMS and that all current is measured by the hall effect current sensor. **It is the user’s responsibility to ensure the BMS is connected to all cells, to verify the BMS has a method to limit current in and out of the pack, and to determine and supply the correct programming parameters (such as maximum cell voltage, minimum cell voltage, maximum temperature, etc).**

6) Because the Orion BMS is connected to a high voltage battery pack, hazardous voltages and hazardous energies may be present inside the unit. There are no user serviceable parts inside the unit and opening the enclosure will void the warranty. Users should never attempt to repair an Orion BMS unit. Further, a damaged unit or a unit repaired without authorization may pose additional safety risks. **DAMAGED UNITS SHOULD BE IMMEDIATELY DISCONNECTED FROM ALL POWER INCLUDING THE BATTERY PACK AND REMOVED FROM SERVICE. NEVER CONTINUE TO USE A DAMAGED BMS UNIT.** Please contact the factory or your local distributor for repair options. Ewert Energy is not liable for damage caused by user attempted repairs or continued use of a damaged BMS unit.

7) While every effort is made to ensure that the Orion BMS operates properly under all conditions, it is the integrator’s responsibility to integrate it properly into the application such that any failure is a safe failure. For more information, please read “Failure Modes” in the operational manual. The integrator is responsible for the determination of suitability of this product for the application, choice of all external components, including, but not limited to, wire, wiring methods, and interconnects, and complying with any regulations, standards, or codes. The Orion BMS is not to be used for life support systems, medical applications or other applications where a failure could cause damage to property or cause bodily harm or death.

8) Paralleling separate strings of li-ion batteries together requires special considerations and a method to isolate each string from each other. The Orion BMS may not be used with parallel string configurations unless specific external safety systems are provided. Engineering work by a qualified electrical engineer is required for use with parallel strings. Generally, one Orion BMS is required per parallel string (in certain specific cases, it may be possible to use a sing unit with reduced accuracy when isolation requirements are met). If you are using the Orion BMS in a parallel string setup, please see our documentation about parallel strings (Note: this is different from paralleling cells inside of a single string which is very common).

9) The BMS chassis must be grounded to properly bypass electrical noise to the chassis ground. A grounding lug is provided for this purpose. Additionally, external tooth lock washers can be used on mounting screws to ensure good electrical connectivity between the chassis and the Orion BMS. Ground straps should be as short as possible using as large gauge wire as possible. **This excludes the Orion BMS Jr.**

10) The BMS unit must be programmed in order to function. BMS units ship from the factory with a profile that will not allow charge or discharge for safety reasons. To program, the BMS must be connected to a PC using the CANdapter. For more information on programming, see the software manual.

## Orion BMS Custom Messages for use with HPEVS

	Length in bytes	ADDRESS ID	
		0x300	0x301
Byte0		Low Cell Voltage High	Pack SOC
Byte1		Low Cell Voltage	High Temperature
Byte2		High Cell Voltage High	n/a
Byte3		High Cell Voltage	DCL High Byte
Byte4		Pack Current High Byte	DCL
Byte5		Pack Current	*Custom Flag
Byte6		Pack Amphours High Byte	Highest Cell Voltage ID
Byte7		Pack Amphours	Lowest Cell Voltage ID

	*Custom Flag for Orion BMS Jr	*Custom Flag for Orion BMS (NOT Jr)
Bit #1	Charge Interlock	Charge Interlock
Bit #2	DTC: Temperature Sensor Fault	DTC: Temperature Sensor Fault
Bit #3	DTC: Weak Cell Fault	DTC: Weak Cell Fault
Bit #4	DTC: Low Cell Voltage Fault	DTC: Low Cell Voltage Fault
Bit #5	DTC: Open Cell Fault	DTC: Open Cell Fault
Bit #6	DTC: BMS Current Sensor Fault	DTC: BMS Current Sensor Fault
Bit #7	DTC: Cell Over 5V	DTC: Cell Over 5V
Bit #8	n/a	DTC: High Voltage Isolation Fault (GFI)

Notes:			
	CAN Bus Baud rate	Message setting transmit speed for mailboxes 0x300 and 0x301	byte order
	250 kbps	104 ms	Big Endian

Address 0x300	
Byte0:	low cell voltage high byte set by multiply by 1 then divide by 10
Byte1:	low cell voltage set by multiply by 1 then divide by 1
Byte2:	high cell voltage high byte set by multiply by 1 then divide by 10
Byte3:	high cell voltage set by multiply by 1 then divide by 1
Byte4:	Pack current high byte set by multiplying by 1 then divide by 1
Byte5:	Pack current set by multiply by 1 then divide by 1
Byte6:	Pack Amphours high byte set by multiplying by 1 then divide by
Byte7:	Pack Amphours set by multiplying by 1 then divide by 1

Address 0x301	
Byte0:	Pack SOC value set by multiplying by 1 then divide by 2
Byte1:	High Temperature set by multiplying by 1 then divide by 1
Byte2:	not used
Byte3:	not used
Byte4:	not used
Byte5:	Custom Flag #3
Byte6:	Highest Cell Voltage ID set by multiplying by 1 then divide by 1
Byte7:	Lowest Cell Voltage ID set by multiplying by 1 then divide by 1



## Generic Software "E" Controller Faults

Code	PROGRAMMER LCD DISPLAY EFFECT OF FAULT	POSSIBLE CAUSE	SET/CLEAR CONDITIONS
12	<b>Controller Overcurrent</b> <i>ShutdownMotor;</i> <i>ShutdownMainContactor;</i> <i>ShutdownEMBrake;</i> <i>ShutdownThrottle;</i> <i>FullBrake;</i> <i>ShutdownPump.</i>	1) External short of phase U, V, or W motor connections 2) Motor parameters are mis-tuned 3) Controller defective 4) Speed encoder noise problems.	<b>Set:</b> Phase current exceeded the current measurement limit <b>Clear:</b> Cycle KSI
13	<b>Current Sensor Fault</b> <i>ShutdownMotor;</i> <i>ShutdownMainContactor;</i> <i>ShutdownEMBrake;</i> <i>ShutdownThrottle;</i> <i>FullBrake;</i> <i>ShutdownPump.</i>	1) Leakage to vehicle frame from phase U, V, or W (short in motor stator) 2) Controller defective	<b>Set:</b> Controller current sensors have invalid reading <b>Clear:</b> Cycle KSI
14	<b>Precharge Failed</b> <i>ShutdownMotor;</i> <i>ShutdownMainContactor;</i> <i>ShutdownEMBrake;</i> <i>ShutdownThrottle;</i> <i>FullBrake;</i> <i>ShutdownPump.</i>	1) External load on capacitor bank (B+ connection terminal) that prevents the capacitor bank from charging	<b>Set:</b> Precharge failed to charge the capacitor bank to KSI voltage <b>Clear:</b> Cycle Interlock input or use VCL function <i>Enable_Precharge()</i>
15	<b>Controller Severe Undertemp</b> <i>ShutdownMotor;</i> <i>ShutdownMainContactor;</i> <i>ShutdownEMBrake;</i> <i>ShutdownThrottle;</i> <i>FullBrake;</i> <i>ShutdownPump.</i>	1) See Monitor menu » Controller: Temperature. 2) Controller is operating in an extreme environment.	<b>Set:</b> Heatsink temperature below -40°C. <b>Clear:</b> Bring heatsink temperature above -40°C, and cycle interlock or KSI.

Code	PROGRAMMER LCD DISPLAY EFFECT OF FAULT	POSSIBLE CAUSE	SET/CLEAR CONDITIONS
16	<p><b>Controller Severe Overtemp</b>  <i>ShutdownMotor;</i>  <i>ShutdownMainContactor;</i>  <i>ShutdownEMBrake;</i>  <i>ShutdownThrottle;</i>  <i>FullBrake;</i>  <i>ShutdownPump.</i></p>	<p>1) See Monitor menu » Controller: Temperature.  2) Controller is operating in an extreme environment.  3) Excessive load on vehicle.  4) Improper mounting of controller.</p>	<p><b>Set:</b> Heatsink temperature above +95°C.  <b>Clear:</b> Bring heatsink temperature below +95°C, and cycle interlock or KSI.</p>
17	<p><b>Severe B+ Undervoltage</b>  <i>Reduced drive torque.</i></p>	<p>1) Battery Menu parameters are misadjusted  2) Non-controller system drain on battery  3) Battery resistance  4) Battery disconnected while driving  5) See Monitor Menu &gt;&gt; Battery: Capacitor voltage  6) Blown B+ fuse or main contactor did not close</p>	<p><b>Set:</b> Capacitor bank voltage dropped below the Severe Undervoltage limit with FET bridge enabled  <b>Clear:</b> Bring capacitor voltage above Severe Undervoltage limit</p>
18	<p><b>Severe B+ Overvoltage</b>  <i>ShutdownMotor;</i>  <i>ShutdownMainContactor;</i>  <i>ShutdownEMBrake;</i>  <i>ShutdownThrottle;</i>  <i>FullBrake;</i>  <i>ShutdownPump.</i></p>	<p>1) See Monitor menu &gt;&gt; Battery: Capacitor Voltage  2) Battery menu parameters are misadjusted  3) Battery resistance too high for given regen current  4) Battery disconnected while regen braking</p>	<p><b>Set:</b> Capacitor bank voltage exceeded the Severe Overvoltage limit with FET bridge enabled  <b>Clear:</b> Bring capacitor voltage below Severe Overvoltage limit and then cycle KSI</p>
22	<p><b>Controller Overtemp Cutback</b>  <i>Reduced drive and brake torque.</i></p>	<p>1) See Monitor menu &gt;&gt; Controller: Temperature  2) Controller is performance-limited at this temperature  3) Controller is operating in an extreme environment  4) Excessive load on vehicle  5) Improper mounting of controller</p>	<p><b>Set:</b> Heatsink temperature exceeded by 85°C  <b>Clear:</b> Bring heatsink temperature below 85°C</p>

Code	PROGRAMMER LCD DISPLAY EFFECT OF FAULT	POSSIBLE CAUSE	SET/CLEAR CONDITIONS
23	<p style="text-align: center;"><b>B+ Undervoltage Cutback</b> <i>Reduced drive torque.</i></p>	<p>1) Normal operation. Fault shows that the batteries need recharging. Controller performance is limited at this voltage.  2) Battery parameters are misadjusted  3) Non-controller system drain on battery  4) Battery resistance too high  5) Battery disconnected while driving  6) See Monitor Menu &gt;&gt; Battery: Capacitor voltage  7) Blown B+ fuse or main contactor did not close</p>	<p><b>Set:</b> Capacitor bank voltage dropped below the Undervoltage limit with the FET bridge enabled  <b>Clear:</b> Bring capacitor voltage below the undervoltage limit</p>
24	<p style="text-align: center;"><b>B+ Overvoltage Cutback</b> <i>Reduced brake torque .</i></p>	<p>1) Normal operation. Fault shows that regen braking currents elevated the battery voltage during regen braking. Controller is performance limited at this voltage.  2) Battery parameters are misadjusted  3) Battery resistance too high for given regen current  4) Battery disconnected while regen braking  5) See Monitor Menu &gt;&gt; Battery: Capacitor voltage</p>	<p><b>Set:</b> Capacitor bank voltage exceeded the Overvoltage limit with the FET bridge enabled  <b>Clear:</b> Bring capacitor voltage below the Overvoltage limit</p>
25	<p style="text-align: center;"><b>5V Supply Failure</b> <i>None, unless a fault action is programmed in VCL.</i></p>	<p>1) External load impedance on the +5V supply (pin 26) is too low  2) See Monitor menu &gt;&gt; outputs: 5 Volts and Ext Supply Current</p>	<p><b>Set:</b> +5V supply (pin 26) outside the +5V +/- 10% range  <b>Clear:</b> Bring voltage within range</p>

Code	PROGRAMMER LCD DISPLAY EFFECT OF FAULT	POSSIBLE CAUSE	SET/CLEAR CONDITIONS
26	<p><b>Digital Out 6 Overcurrent</b> <i>Digital Output 6 driver will not turn on.</i></p>	<p>1. External load impedance on Digital Output 6 driver (pin 19) is too low.</p>	<p><b>Set:</b> Digital Output 6 (pin 19) current exceeded 15 mA. <b>Clear:</b> Remedy the overcurrent cause and use the VCL function Set_DigOut() to turn the driver on again.</p>
27	<p><b>Digital Out 7 Overcurrent</b> <i>Digital Output 7 driver will not turn on.</i></p>	<p>1) External load impedance on Digital Output 7 driver (pin 20) is too low.</p>	<p><b>Set:</b> Digital Output 7 (pin 20) current exceeded 15 mA. <b>Clear:</b> Remedy the overcurrent cause and use the VCL function Set_DigOut() to turn the driver on again.</p>
28	<p><b>Motor Temp Hot Cutback</b> <i>Reduced drive torque.</i></p>	<p>1) Motor temperature is at or above the programmed Temperature Hot setting, and the requested current is being cut back 2) Motor Temperature Control Menu parameters are mis-tuned 3) See Monitor Menu &gt;&gt; Motor: Temperature and &gt;&gt; Inputs: Analog2 4) If the application doesn't use a motor thermistor, Temp Compensation and Temp Cutback should be programmed Off.</p>	<p><b>Set:</b> Motor temperature is at or above the Temperature Hot parameter setting. <b>Clear:</b> Bring the motor temperature within range</p>
29	<p><b>Motor Temp Sensor Fault</b> <i>MaxSpeed reduced (LOS, Limited Operating Strategy), and motor temperature cutback disabled.</i></p>	<p>1) Motor thermistor is not connected properly 2) If the application doesn't use a motor thermistor. Motor Temp Sensor Enable should be programmed OFF 3) See Monitor Menu &gt;&gt; Motor: Temperature and &gt;&gt; Inputs: Analog2</p>	<p><b>Set:</b> Motor thermistor input (pin 8) is at the voltage rail (0 or 10V) <b>Clear:</b> Bring the motor thermistor input voltage within range</p>

Code	PROGRAMMER LCD DISPLAY EFFECT OF FAULT	POSSIBLE CAUSE	SET/CLEAR CONDITIONS
31	<p style="text-align: center;"><b>Coil1 Driver Open/Short</b> <i>ShutdownDriver1.</i></p>	<p>1) Open or short on driver load 2) Dirty connector pins 3) Bad crimps or faulty wiring</p>	<p><b>Set:</b> Driver 1 (pin 6) is either open or shorted. This fault can be set only when Main Enable = OFF <b>Clear:</b> Correct open or short and cycle driver</p>
31	<p style="text-align: center;"><b>Main Open/Short</b> <i>ShutdownMotor;</i> <i>ShutdownMainContactor;</i> <i>ShutdownEMBrake;</i> <i>ShutdownThrottle;</i> <i>FullBrake;</i> <i>ShutdownPump.</i></p>	<p>1) Open or short on driver load 2) Dirty connector pins 3) Bad crimps or faulty wiring</p>	<p><b>Set:</b> Main contactor driver (pin 6) is either open or shorted. This fault can be set only when Main Enable = ON <b>Clear:</b> Correct open or short, and cycle driver</p>
32	<p style="text-align: center;"><b>Coil2 Driver Open/Short</b> <i>ShutdownDriver2.</i></p>	<p>1) Open or short on driver load. 2) Dirty connector pins. 3) Bad crimps or faulty wiring.</p>	<p><b>Set:</b> Driver 2 (pin 5) is either open or shorted. This fault can be set only when EM Brake Type = 0. <b>Clear:</b> Correct open or short, and cycle driver.</p>
32	<p style="text-align: center;"><b>EMBrake Open/Short</b> <i>ShutdownEMBrake;</i> <i>ShutdownThrottle;</i> <i>FullBrake.</i></p>	<p>1) Open or short on driver load. 2) Dirty connector pins. 3) Bad crimps or faulty wiring.</p>	<p><b>Set:</b> Electromagnetic brake driver (pin 5) is either open or shorted. This fault can be set only when EM Brake Type &gt; 0. <b>Clear:</b> Correct open or short, and cycle driver.</p>

Code	PROGRAMMER LCD DISPLAY EFFECT OF FAULT	POSSIBLE CAUSE	SET/CLEAR CONDITIONS
33	<b>Coil3 Driver Open/Short</b> <i>ShutdownDriver3.</i>	1) Open or short on driver load. 2) Dirty connector pins. 3) Bad crimps or faulty wiring.	<b>Set:</b> Driver 3 (pin 4) is either open or shorted. <b>Clear:</b> Correct open or short, and cycle driver.
34	<b>Coil4 Driver Open/Short</b> <i>ShutdownDriver4.</i>	1) Open or short on driver load. 2) Dirty connector pins. 3) Bad crimps or faulty wiring.	<b>Set:</b> Driver 4 (pin 3) is either open or shorted. <b>Clear:</b> Correct open or short, and cycle driver.
35	<b>PD Open/Short</b> <i>ShutdownPD.</i>	1) Open or short on driver load. 2) Dirty connector pins. 3) Bad crimps or faulty wiring.	<b>Set:</b> Proportional driver (pin 2) is either open or shorted. <b>Clear:</b> Correct open or short, and cycle driver.
36	<b>Encoder Fault</b> <i>ShutdownEMBrake;</i> <i>ShutdownThrottle.</i>	1) Motor encoder failure 2) Bad crimps or faulty wiring 3) See Monitor menu >> Motor: Motor RPM	<b>Set:</b> Motor encoder phase failure detected. <b>Clear:</b> Cycle KSI
36	<b>Sin/Cos Sensor Fault</b> <i>ShutdownEMBrake;</i> <i>ShutdownThrottle.</i>	1) SPMSM motor characterization not completed or poorly matched to motor. 2) Sin/cos feedback sensor failure. 3) Bad crimps or faulty wiring. 4) See Monitor menu » Motor: Sin Input A and Sin Input B. 5) See Monitor menu » Motor: Motor RPM.	<b>Set:</b> Sin/cos sensor output failure detected. <b>Clear:</b> Cycle KSI.
37	<b>Motor Open</b> <i>ShutdownMotor;</i> <i>ShutdownMainContactor;</i> <i>ShutdownEMBrake;</i> <i>ShutdownThrottle;</i> <i>FullBrake;</i> <i>ShutdownPump.</i>	1) Motor phase is open 2) Bad crimps or faulty wiring	<b>Set:</b> Motor phase U, V or W detected open <b>Clear:</b> Cycle KSI

Code	PROGRAMMER LCD DISPLAY EFFECT OF FAULT	POSSIBLE CAUSE	SET/CLEAR CONDITIONS
38	<p><b>Main Contactor Welded</b>  <i>ShutdownMotor;</i>  <i>ShutdownMainContactor;</i>  <i>ShutdownEMBrake;</i>  <i>ShutdownThrottle;</i>  <i>FullBrake;</i>  <i>ShutdownPump.</i></p>	<p>1) Main contactor tips are welded closed  2) Motor phase U or V is disconnected or open  3) An alternative voltage path (such as an external precharge resistor) is providing a current to the capacitor bank (B+ connection terminal)</p>	<p><b>Set:</b> Just prior to the main contactor closing, the capacitor bank voltage (B+ connection terminal) was loaded for a short time and the voltage did not discharge  <b>Clear:</b> Cycle KSI</p>
39	<p><b>Main Contactor Did Not Close</b>  <i>ShutdownMotor;</i>  <i>ShutdownMainContactor;</i>  <i>ShutdownEMBrake;</i>  <i>ShutdownThrottle;</i>  <i>FullBrake;</i>  <i>ShutdownPump.</i></p>	<p>1) Main contactor did not close  2) Main contactor tips are oxidized, burned, or not making good contact  3) External load on capacitor bank (B+ connection terminal) that prevents capacitor bank from charging  4) Blown B+ fuse</p>	<p><b>Set:</b> With the main contactor commanded closed, the capacitor bank voltage (B+ connection terminal) did not charge to B+  <b>Clear:</b> Cycle KSI</p>
41	<p><b>Throttle Wiper High</b>  <i>ShutdownThrottle.</i></p>	<p>1) See Monitor Menu &gt;&gt; Inputs: Throttle Pot  2) Throttle pot wiper voltage too high</p>	<p><b>Set:</b> Throttle pot wiper (pin 16) voltage is higher than the high fault threshold (can be changed with the VCL function <i>Setup_Pot_Faults()</i> )  <b>Clear:</b> Bring throttle pot wiper voltage below the fault threshold</p>
42	<p><b>Throttle Wiper Low</b>  <i>ShutdownThrottle.</i></p>	<p>1) See Monitor Menu &gt;&gt; Inputs: Throttle Pot  2) Throttle pot wiper voltage too low</p>	<p><b>Set:</b> Throttle pot wiper (pin 16) voltage is lower than the low fault threshold (can be changed with the VCL function <i>Setup_Pot_Faults()</i>)  <b>Clear:</b> Bring throttle pot wipervoltage above the fault threshold</p>

Code	PROGRAMMER LCD DISPLAY EFFECT OF FAULT	POSSIBLE CAUSE	SET/CLEAR CONDITIONS
43	<p style="text-align: center;"><b>Pot2 Wiper High</b> <i>FullBrake.</i></p>	<p>1) See Monitor Menu &gt;&gt; Inputs: Pot2 Raw 2) Pot2 wiper voltage too high</p>	<p><b>Set:</b> Pot2 wiper (pin 17) voltage is higher than the high fault threshold (can be changed with the VCL function <i>Setup_Pot_Faults()</i> ) <b>Clear:</b> Bring Pot2 wiper voltage below the fault threshold</p>
44	<p style="text-align: center;"><b>Pot2 Wiper Low</b> <i>FullBrake.</i></p>	<p>1) See Monitor Menu &gt;&gt; Inputs: Pot2 Raw 2) Pot2 wiper voltage too low</p>	<p><b>Set:</b> Pot2 wiper (pin 17) voltage is lower than the low fault threshold (can be changed with the VCL function <i>Setup_Pot_Faults()</i>) <b>Clear:</b> Bring Pot2 wiper voltage above the fault threshold</p>
45	<p style="text-align: center;"><b>Pot Low Overcurrent</b> <i>ShutdownThrottle;</i> <i>FullBrake.</i></p>	<p>1) See Monitor Menu &gt;&gt; Outputs: Pot Low 2) Combined pot resistance connected to pot low is too low</p>	<p><b>Set:</b> Pot low (pin 18) current exceeds 10mA <b>Clear:</b> Clear pot low overcurrent condition and cycle KSI</p>



Code	PROGRAMMER LCD DISPLAY EFFECT OF FAULT	POSSIBLE CAUSE	SET/CLEAR CONDITIONS
46	<p style="text-align: center;"><b>EEPROM Failure</b>  <i>ShutdownMotor;</i>  <i>ShutdownMainContactor;</i>  <i>ShutdownEMBrake;</i>  <i>ShutdownThrottle;</i>  <i>ShutdownInterlock;</i>  <i>ShutdownDriver1;</i>  <i>ShutdownDriver2;</i>  <i>ShutdownDriver3;</i>  <i>ShutdownDriver4;</i>  <i>ShutdownPD;</i>  <i>FullBrake;</i>  <i>ShutdownPump.</i></p>	<p>1) Failure to write to EEPROM memory. This can be caused by EEPROM memory writes initiated by VCL, by the CAN bus, by adjusting parameters with the programmer, or by loading new software into the controller</p>	<p><b>Set:</b> Controller operating system tried to write to EEPROM memory and failed.  <b>Clear:</b> Download the correct software (OS) and matching parameter default settings into the controller and cycle KSI</p>
47	<p style="text-align: center;"><b>HPD/Sequencing Fault</b>  <i>ShutdownThrottle.</i></p>	<p>1. KSI, interlock, direction, and throttle inputs applied in incorrect sequence.  2. Faulty wiring, crimps, or switches KSI, interlock, direction, or throttle inputs.</p>	<p><b>Set:</b> HPD (High Pedal Disable) or sequencing fault caused by incorrect sequence of KSI, interlock, direction, and throttle inputs.  <b>Clear:</b> Reapply inputs in correct sequence.</p>
47	<p style="text-align: center;"><b>Emer Rev HPD</b>  <i>ShutdownThrottle;</i>  <i>ShutdownEMBrake.</i></p>	<p>1) Emergency Reverse operation has concluded, but the throttle, forward and reverse inputs, and interlock have not been returned to neutral.</p>	<p><b>Set:</b> At the conclusion of Emergency Reverse, the fault was set because various inputs were not returned to neutral.  <b>Clear:</b> If EMR_Interlock = On, clear the interlock, throttle, and direction inputs. If EMR_Interlock = Off, clear the throttle and direction inputs.</p>

Code	PROGRAMMER LCD DISPLAY EFFECT OF FAULT	POSSIBLE CAUSE	SET/CLEAR CONDITIONS
49	<b>Parameter Change Fault</b> <i>ShutdownMotor;</i> <i>ShutdownMainContactor;</i> <i>ShutdownEMBrake;</i> <i>ShutdownThrottle;</i> <i>FullBrake;</i> <i>ShutdownPump.</i>	1) This is a safely fault caused by a change in certain parameter settings so that the vehicle will not operate until KSI is cycled. For example, if a user changes the Throttle Type this fault will appear and require cycling KSI before the vehicle can operate.	<b>Set:</b> Adjustment of a parameter setting that requires cycling of KSI <b>Clear:</b> Cycle KSI
51	<b>Motor Type Parameter Change</b> <i>ShutdownMotor;</i> <i>ShutdownMainContactor;</i> <i>ShutdownEMBrake;</i> <i>ShutdownThrottle;</i> <i>FullBrake;</i> <i>ShutdownPump.</i>	1) Motor Type was changed when the system was up and running.	<b>Set:</b> Motor Type Change <b>Clear:</b> Cycle KSI
52	<b>Fault from Secondary</b>	1) The secondary controller that is used in a dual motor configuration has a fault.	<b>Set:</b> Fault from Secondary <b>Clear:</b> Check and clear fault that exists on secondary controller; Cycle KSI
53	<b>Software License Violation</b>	1)The software that has been installed violates the license agreement between the software and the controller	<b>Set:</b> The license of the installed software package does not match the license of the controller. <b>Clear:</b> <b>Contact HPEVS</b>
54	<b>Secondary Communication Error</b>	1) No power to secondary controller. 2) Broken wire in the CAN BUS wiring. 3) Faulty secondary controller.	<b>Set:</b> Secondary controller not powered. Broken wire within the CAN BUS wiring harness. Faulty secondary controller. <b>Clear:</b> Check wiring and make sure that controller is powering up. Check the CAN BUS wiring to secondary controller for continuity. Replace the secondary controller.
55	<b>Program Mode</b>	1) Primary controller in program mode	<b>Set:</b> Primary controller in program mode by user <b>Clear:</b> Complete program functions in primary controller and cycle KSI

Code	PROGRAMMER LCD DISPLAY EFFECT OF FAULT	POSSIBLE CAUSE	SET/CLEAR CONDITIONS
56	<b>Diagnostic Mode</b>	1) Primary controller in diagnostic mode	<b>Set:</b> Primary controller in diagnostic mode by user <b>Clear:</b> Complete diagnostic mode functions in primary controller and cycle KSI
57	<b>BMS COMM Fault</b>	1) BMS communication has stopped or never started	<b>Set:</b> BMS communication fault detected <b>Clear:</b> Check CAN BUS wiring and connectors for loose or recessed pins in the connector or cut/broken wires
58	<b>Charger plugged in</b>	1) The charger is plugged into the vehicle. This code is set to advise and is not an actual controller fault.	<b>Set:</b> The charger is plugged into the vehicle. <b>Clear:</b> Remove plug.

Code	PROGRAMMER LCD DISPLAY EFFECT OF FAULT	POSSIBLE CAUSE	SET/CLEAR CONDITIONS
59	<p align="center"><b>BMS FAULT</b> <i>Charger Safety</i></p>	<p>1) The limit enforcement faults are caused when charge or discharge current (respectively) either exceeds the limit set by the BMS or continues after the digital on/off outputs are turned off.</p> <p><i>This error can be falsely triggered if the current sensor polarity is backwards.</i></p>	<p><b>Clear:</b></p> <ol style="list-style-type: none"> <li>1. Immediately ensure that the pack is not being over-discharged or over-charged. The BMS is indicating that it does not appear to have control over charge and discharge which can lead to dangerous conditions.</li> <li>2. Ensure the correct orientation of the current sensor. Current going into the battery pack should read negative and current leaving the battery pack should show up as positive. If the current sensor is backwards, it charge current will register as discharge current.</li> </ol>
61	<p align="center"><b>BMS FAULT</b> <i>Thermistor Fault</i></p>	<p>1) A thermistor fault is triggered detected if the analog voltage measured from the thermistor is outside of the normal operating range.</p>	<p><b>Clear:</b></p> <ol style="list-style-type: none"> <li>1. Check the thermistor wiring and ensure that the thermistors are wired properly. If the thermistor connector was not installed when the BMS was powered up, this error will result. Clear the error codes or restart the BMS if the connector was connected after the BMS was powered up.</li> <li>2. Check for any shorts on the thermistor wires. If the thermistors have been extended or modified then these areas would be the best place to check first.</li> </ol>

Code	PROGRAMMER LCD DISPLAY EFFECT OF FAULT	POSSIBLE CAUSE	SET/CLEAR CONDITIONS
62	<p align="center"><b>BMS FAULT</b> <i>Weak Cell Fault</i></p>	<p>1) The BMS is aware of the nominal (normal) Internal Resistance of the battery pack based on the data entered into the Nominal Cell Resistance table. This value is used to determine the maximum allowable internal resistance for a cell before it is determined to be weak or faulty.</p> <p>2) The BMS will also set a weak cell fault code if the difference between the open (sitting) cell voltage of any one cell and the average of the rest of the cells is too great.</p>	<p><b>Set:</b> A weak cell fault indicates when the pack cell drops below a programmed value.</p> <p><b>Clear:</b> Replace offending pack cell</p>
63	<p align="center"><b>BMS FAULT</b> <i>Low Cell Voltage Fault</i></p>	<p>1) This fault code is triggered simply when the voltage of a cell falls below 0.09 volts (90 mV).</p>	<p><b>Set:</b></p> <ol style="list-style-type: none"> <li>1) This fault can be caused by a cell that is incorrectly set in the BMS profile as a populated cell</li> <li>2) A disconnected cell wiring harness</li> <li>3) A very dead cell</li> <li>4) A wiring error</li> </ol> <p><b>Clear:</b></p> <ol style="list-style-type: none"> <li>1) Using the Orion BMS utility, identify all affected cells listed on the far right hand side of the diagnostic trouble code screen.</li> <li>2) Ensure that the cell voltage tap wiring harnesses are connected to the proper connectors.</li> <li>3) Measure the actual cell voltage using a multimeter. If cell voltage does not match the voltage reported in the BMS, there likely is a wiring error and/or internal damage to the BMS unit.</li> </ol>

Code	PROGRAMMER LCD DISPLAY EFFECT OF FAULT	POSSIBLE CAUSE	SET/CLEAR CONDITIONS
64	<p style="text-align: center;"><b>BMS FAULT</b> <i>Open Cell Voltage Fault</i></p>	<p>1. When diagnosing errors this error code should be corrected first. This error code indicates that the Orion BMS has determined that a cell tap wire is either weakly connected or not connected and as a result, it has determined that it cannot accurately measure cell voltages.</p> <p><b>Warning: Never continue to use a damaged unit. Damaged units must be immediately disconnected from all wiring harnesses and power sources including cell taps and Main I/O</b></p>	<p><b>Set:</b> A single open wire (wiring fault) in a cell group may cause cell voltages in the rest of the cell group to be incorrectly measured. Cell voltages may read artificially higher or lower due to the effects of the protection diodes contained within the Orion BMS and cannot be trusted when this error message is present</p> <p><b>Clear:</b></p> <ol style="list-style-type: none"> <li>1) The Orion BMS utility will indicate which cell tap numbers the BMS has detected are open.</li> <li>2) Test the wiring harness with the Orion BMS tap validation tool.</li> <li>3) If the BMS has been previously wired incorrectly, it is possible internal damage to the BMS can cause this fault condition.</li> </ol>

Code	PROGRAMMER LCD DISPLAY EFFECT OF FAULT	POSSIBLE CAUSE	SET/CLEAR CONDITIONS
65	<p align="center"><b>BMS FAULT</b> <i>Current Sensor Fault</i></p>	<p>1) A current sensor fault is triggered if the analog voltages from the attached current sensor stray outside of the normal range or if the values</p> <p><b>This error code will cause the BMS to enter a current sensor failsafe mode</b></p>	<p><b>Clear:</b></p> <p>1) Check to ensure that the current sensor is properly connected to the BMS. The majority of current sensor faults turn out to be wiring faults</p> <p>2) This fault code can be triggered by currents exceeding 120% of the current sensor rating</p> <p>3) Swapping out the current sensor and wiring harness with a known good sensor and harness. If this does not resolve the problem, contact the factory for testing and repair options for the Orion BMS unit.</p>
66	<p align="center"><b>BMS FAULT</b> <i>Cell Voltage Over 5 Volts</i></p>	<p>1) This fault code is triggered if the voltage of an individual cell (as measured by the BMS) exceeds 5.0 volts. This fault code will only trigger after a number of samplings over the period of 1 minute to prevent false positives. <b><i>If this fault triggers, it will cause the BMS to enter into a voltage failsafe condition disabling all charge and discharge.</i></b></p> <p><b><i>Used with Orion BMS Jr.</i></b></p>	<p><b>Set:</b> This fault code is set if the voltage of an individual cell (as measured by the BMS) exceeds 5.0 volts</p> <p><b>Clear:</b></p> <p>1) Cells which have been over-charged or over-discharged may not be safe to use even after bringing the voltage into a correct range. A cell which has previously been over-charged or over-discharged at any time may develop internal damage, compromising the safety of the cell. Always consult the cell manufacturer for advice on whether a cell can be safely used after an over-charge or over-discharge event</p>

Code	PROGRAMMER LCD DISPLAY EFFECT OF FAULT	POSSIBLE CAUSE	SET/CLEAR CONDITIONS
67	<p style="text-align: center;"><b>BMS FAULT</b> <i>High Voltage Isolation Fault</i></p>	<p>1) A breakdown in isolation can be caused by ruptured or leaking cells, high voltage cabling insulation that has rubbed off and come into contact with low voltage systems, condensation, use of non-isolated equipment, other causes or by an intentionally non-isolated design.</p> <p><b>This error code may indicate an unsafe condition that exists in the battery pack and care must be taken to avoid risk of short circuit and risk of personal injury from shock while investigating the error as simply touching a cell could cause a shock.</b></p> <p><b>Used with Orion BMS other than Jr.</b></p>	<p><b>Set:</b> This code is set when the BMS measures an isolation breakdown between the high voltage battery and the 12 volt system</p> <p><b>Clear:</b></p> <p>1) Determine if the system is supposed to be isolated and if other isolation detection circuits are connected at the same time. If the overall system is intentionally designed to be non-isolated, isolation fault detection should be disabled. Other isolation fault detection circuits operating on the same battery pack may interfere with each other and cause false readings.</p>



Code	PROGRAMMER LCD DISPLAY EFFECT OF FAULT	POSSIBLE CAUSE	SET/CLEAR CONDITIONS
68	<p style="text-align: center;"><b>VCL Run Time Error</b></p> <p style="text-align: center;"><i>ShutdownMotor;</i> <i>ShutdownMainContactor;</i> <i>ShutdownEMBrake;</i> <i>ShutdownThrottle;</i> <i>ShutdownInterlock;</i> <i>ShutdownDriver1;</i> <i>ShutdownDriver2;</i> <i>ShutdownDriver3;</i> <i>ShutdownDriver4;</i> <i>ShutdownPD;</i> <i>FullBrake;</i> <i>ShutdownPump.</i></p>	<p>1) VCL code encountered a runtime VCL error</p> <p>2) See Monitor Menu &gt;&gt; Controller: VCL Error Module and VCL Error. This error can then be compared to the runtime VCL module ID and error code definitions found in the specific OS system information file.</p>	<p><b>Set:</b> Runtime VCL code error condition</p> <p><b>Clear:</b> Edit VCL application software to fix this error condition; flash the new complied software and matching parameter defaults; cycle KSI</p>
69	<p style="text-align: center;"><b>External Supply Out of Range</b></p>	<p>1) External load on the 5V and 12V supplies draws either too much or too little current</p> <p>2) Fault Checking Menu parameters Ext Supply Max and Ext Supply Min are mis-tuned</p> <p>3) See Monitor Menu &gt;&gt; Options: Ext Supply Current</p>	<p><b>Set:</b> The external supply current (combined current used by the 5V supply [pin 26] and the 12V supply [pin 25]) is either greater than the upper current threshold or lower than the lower current threshold. The two thresholds are defined by the External Supply Max and External Supply Min parameter settings.</p> <p><b>Clear:</b> Bring the external supply current within range</p>

Code	PROGRAMMER LCD DISPLAY EFFECT OF FAULT	POSSIBLE CAUSE	SET/CLEAR CONDITIONS
71	<p style="text-align: center;"><b>OS General</b></p> <p style="text-align: center;"><i>ShutdownMotor;</i> <i>ShutdownMainContactor;</i> <i>ShutdownEMBrake;</i> <i>ShutdownThrottle;</i> <i>ShutdownInterlock;</i> <i>ShutdownDriver1;</i> <i>ShutdownDriver2;</i> <i>ShutdownDriver3;</i> <i>ShutdownDriver4;</i> <i>ShutdownPD;</i> <i>FullBrake;</i> <i>ShutdownPump.</i></p>	1) Internal controller fault.	<p><b>Set:</b> Internal controller fault detected.</p> <p><b>Clear:</b> Cycle KSI.</p>
72	<p style="text-align: center;"><b>PDO Timeout</b></p> <p style="text-align: center;"><i>ShutdownThrottle;</i> <i>CAN NMT State set to Pre-operational.</i></p>	1) Time between CAN PDO messages received exceeded the PDO Timeout Period.	<p><b>Set:</b> Time between CAN PDO messages received exceeded the PDO Timeout Period.</p> <p><b>Clear:</b> Cycle KSI or receive CAN NMT message.</p>
73	<p style="text-align: center;"><b>Stall Detected</b></p> <p style="text-align: center;"><i>ShutdownEMBrake;</i> <i>Control Mode changed to LOS (Limited Operating Strategy).</i></p>	1) Stalled Motor 2) Motor encoder failure 3) Bad crimps or faulty wiring 4) Problems with power supply for the motor encoder 5) See Monitor Menu >> Motor: Motor RPM	<p><b>Set:</b> No motor encoder movement detected</p> <p><b>Clear:</b> Either cycle KSI or detect valid motor encoder signals while operating in LOS mode and return Throttle Command = 0 and Motor RPM = 0</p>

Code	PROGRAMMER LCD DISPLAY EFFECT OF FAULT	POSSIBLE CAUSE	SET/CLEAR CONDITIONS
77	<b>Supervisor Fault</b> <i>ShutdownMotor;</i> <i>ShutdownMainContactor;</i> <i>ShutdownEMBrake;</i> <i>ShutdownThrottle;</i> <i>ShutdownInterlock;</i> <i>ShutdownDriver1;</i> <i>ShutdownDriver2;</i> <i>ShutdownDriver3;</i> <i>ShutdownDriver4;</i> <i>ShutdownPD;</i> <i>FullBrake;</i> <i>ShutdownPump.</i>	1) The Supervisor has detected a mismatch in redundant readings. 2) Internal damage to Supervisor microprocessor. 3) Switch inputs allowed to be within upper and lower thresholds for over over 100 milliseconds.	<b>Set:</b> Mismatched redundant readings; damaged Supervisor; illegal switch inputs. <b>Clear:</b> Check for noise or voltage drift in all switch inputs; check connections; cycle KSI.
78	<b>Supervisor Incompatible</b> <i>ShutdownMotor;</i> <i>ShutdownMainContactor;</i> <i>ShutdownEMBrake;</i> <i>ShutdownThrottle;</i> <i>ShutdownInterlock;</i> <i>ShutdownDriver1;</i> <i>ShutdownDriver2;</i> <i>ShutdownDriver3;</i> <i>ShutdownDriver4;</i> <i>ShutdownPD;</i> <i>FullBrake;</i> <i>ShutdownPump.</i>	1) The main OS is not compatible with the Supervisor OS.	<b>Set:</b> Incompatible software. <b>Clear:</b> Load properly matched OS code or update the Supervisor code; cycle KSI.
82	<b>Bad Calibrations</b> <i>ShutdownMotor;</i> <i>ShutdownMainContactor;</i> <i>ShutdownEMBrake;</i> <i>ShutdownThrottle;</i> <i>FullBrake;</i> <i>ShutdownPump.</i>	1) Internal controller fault.	<b>Set:</b> Internal controller fault detected. <b>Clear:</b> Correct fault; cycle KSI.

Code	PROGRAMMER LCD DISPLAY EFFECT OF FAULT	POSSIBLE CAUSE	SET/CLEAR CONDITIONS
83	<p style="text-align: center;"><b>Driver Supply Fault</b>  <i>ShutdownMotor;</i>  <i>ShutdownMainContactor;</i>  <i>ShutdownEMBrake;</i>  <i>ShutdownThrottle;</i>  <i>FullBrake;</i>  <i>ShutdownPump.</i></p>	<p>1) Internal controller fault in the voltage supply for the driver circuits.</p>	<p><b>Set:</b> Internal controller fault detected.  <b>Clear:</b> Cycle KSI.</p>
84	<p style="text-align: center;"><b>Following Error Fault</b>  <i>ShutdownMotor;</i>  <i>ShutdownMainContactor;</i>  <i>ShutdownEMBrake;</i>  <i>ShutdownThrottle;</i>  <i>FullBrake;</i>  <i>ShutdownPump.</i></p>	<p>1) Motor speed was detected not following the commanded speed trajectory within the programmed limits.  2) See Program menu » 1-Speed Mode » Speed Controller »Following Error Limit and Following Error Time.  3) See Monitor menu » Motor Tuning » Speed Error.</p>	<p><b>Set:</b> With Control Mode Select = 0 or 1 Speed Mode Express or Speed Mode), motor speed error detected outside the programmed limits.  <b>Clear:</b> Cycle KSI.</p>

Code	PROGRAMMER LCD DISPLAY EFFECT OF FAULT	POSSIBLE CAUSE	SET/CLEAR CONDITIONS
87	<p style="text-align: center;"><b>Motor Characterization Fault</b>  <i>ShutdownMotor;</i>  <i>ShutdownMainContactor;</i>  <i>ShutdownEMBrake;</i>  <i>ShutdownThrottle;</i>  <i>FullBrake;</i>  <i>ShutdownPump.</i></p>	<p>1.) Motor characterization failed during characterization process. See Monitormenu » Controller: Motor Characterization Error for cause:  0=none  1=encoder signal seen, but step size not determined; set Encoder Step Size manually  2=motor temp sensor fault  3=motor temp hot cutback fault  4= controller overtemp cutback fault  5=controller undertemp cutback fault  6=undervoltage cutback fault  7=severe overvoltage fault  8=encoder signal not seen, or one or both channels missing  9=motor parameters out of characterization range.  20=sin/cos sensor not found.  21=phasing not detected.  22=sin/cos sensor characterization failure.  23=started characterization procedure while motor rotating.</p>	<p><b>Set:</b> Motor characterization failed during the motor characterization process.  <b>Clear:</b> Correct fault; cycle KSI.  <b>Notes:</b>  Errors 1 and 8 apply to ACIM motors only.  Errors 20, 21, and 23 apply to SPMSM motors only. Errors indicate the motor characterization data is invalid, except in the case of Error 1.</p>

Code	PROGRAMMER LCD DISPLAY EFFECT OF FAULT	POSSIBLE CAUSE	SET/CLEAR CONDITIONS
88	<b>Encoder Steps Count Fault</b> <i>ShutdownMotor;</i> <i>ShutdownMainContactor;</i> <i>ShutdownEMBrake;</i> <i>ShutdownThrottle;</i> <i>ShutdownInterlock;</i> <i>ShutdownDriver1;</i> <i>ShutdownDriver2;</i> <i>ShutdownDriver3;</i> <i>ShutdownDriver4;</i> <i>ShutdownPD;</i> <i>FullBrake;</i> <i>ShutdownPump.</i>	1) Encoder Steps parameter does not match the actual motor encoder.	<b>Set:</b> Motor lost IFO control and accelerated without throttle command. <b>Clear:</b> Ensure the Encoder Steps parameter matches the actual encoder; cycle KSI.
89	<b>Motor Type Fault</b> <i>ShutdownMotor;</i> <i>ShutdownMainContactor;</i> <i>ShutdownEMBrake;</i> <i>ShutdownThrottle;</i> <i>FullBrake;</i> <i>ShutdownPump.</i>	1) The Motor_Type parameter value is out of range.	<b>Set:</b> Motor_Type parameter is set to an illegal value. <b>Clear:</b> Set Motor_Type to correct value and cycle KSI.
91	<b>VCL/OS Mismatch</b> <i>ShutdownMotor;</i> <i>ShutdownMainContactor;</i> <i>ShutdownEMBrake;</i> <i>ShutdownThrottle;</i> <i>ShutdownInterlock;</i> <i>ShutdownDriver1;</i> <i>ShutdownDriver2;</i> <i>ShutdownDriver3;</i> <i>ShutdownDriver4;</i> <i>ShutdownPD;</i> <i>FullBrake;</i> <i>ShutdownPump.</i>	1) The VCL software in the controller does not match the OS software in the controller.	<b>Set:</b> VCL and OS software do not match; when KSI cycles, a check is made to verify that they match and a fault is issued when they do not. <b>Clear:</b> Download the correct VCL and OS software into the controller.

Code	PROGRAMMER LCD DISPLAY EFFECT OF FAULT	POSSIBLE CAUSE	SET/CLEAR CONDITIONS
92	<p><b>EM Brake Failed to Set</b>  <i>ShutdownEMBrake;</i>  <i>ShutdownThrottle;</i>  <i>Position Hold is engaged when Interlock=On.</i></p>	<p>1) Vehicle movement sensed after the EM Brake has been commanded to set.  2) EM Brake will not hold the motor from rotating.</p>	<p><b>Set:</b> After the EM Brake was commanded to set and time has elapsed to allow the brake to fully engage, vehicle movement has been sensed.  <b>Clear:</b> Activate the throttle.</p>
93	<p><b>Encoder LOS (Limited Operating Strategy)</b>  <i>Enter LOS control mode.</i></p>	<p>1) Limited Operating Strategy (LOS) control mode has been activated, as a result of either an Encoder Fault (Code 36) or a Stall Detect Fault (Code 73).  2) Motor encoder failure.  3) Bad crimps or faulty wiring.  4) Vehicle is stalled.</p>	<p><b>Set:</b> Encoder Fault (Code 36) or Stall Detect Fault (Code 73) was activated, and Brake or Interlock has been applied to activate LOS control mode, allowing limited motor control.  <b>Clear:</b> Cycle KSI or, if LOS mode was activated by the Stall Fault, clear by ensuring encoder senses proper operation, Motor RPM = 0, and Throttle Command = 0.</p>
94	<p><b>EMR Rev Timeout</b>  <i>ShutdownEMBrake;</i>  <i>ShutdownThrottle;</i></p>	<p>1) Emergency Reverse was activated and concluded because the EMR Timeout timer has expired.  2) The emergency reverse input is stuck On.</p>	<p><b>Set:</b> Emergency Reverse was activated and ran until the EMR Timeout timer expired.  <b>Clear:</b> Turn the emergency reverse input Off.</p>
98	<p><b>Illegal Model Number</b>  <i>ShutdownMotor;</i>  <i>ShutdownMainContactor;</i>  <i>ShutdownEMBrake;</i>  <i>ShutdownThrottle;</i>  <i>FullBrake;</i>  <i>ShutdownPump.</i></p>	<p>1) Model_Number variable contains illegal value. For 1234E/36E/38E models, a value other than 1234, 1236, 1238, or 1298 is illegal. For 1232E models, a value other than 1232 is illegal.  2) Software and hardware do not match.  3) Controller defective.</p>	<p><b>Set:</b> Illegal Model_Number variable; when KSI cycles, a check is made to confirm a legal Model_Number, and a fault is issued if one is not found.  <b>Clear:</b> Download appropriate software for your controller model.</p>

Code	PROGRAMMER LCD DISPLAY EFFECT OF FAULT	POSSIBLE CAUSE	SET/CLEAR CONDITIONS
99	<p style="text-align: center;"><b>Parameter Mismatch Fault</b></p> <p style="text-align: center;"><i>ShutdownMotor;</i> <i>ShutdownMainContactor;</i> <i>ShutdownEMBrake;</i> <i>ShutdownThrottle;</i> <i>FullBrake;</i> <i>ShutdownPump.</i></p>	<p>1) Dual Motor Enable parameter set On and Control Mode Select parameter not set to 1 (Speed Mode Express) or 2 (Speed Mode).</p> <p>2) Motor Technology and Feedback Type parameters do not match.</p>	<p><b>Set:</b> When the Dual Drive software is enabled, the controller must be set to either Speed Mode Express or Speed Mode; otherwise this fault is set. Motor Technology=0 must be paired with Feedback Type=1, and Motor Technology=1 must be paired with Feedback Type=2; otherwise this fault is set.</p> <p><b>Clear:</b> Adjust parameters to appropriate values and cycle KSI.</p>



## GLOSSARY OF TERMS

1. **Accel Rate:** sets the rate (in seconds) at which the motor torque increases to full when full throttle is applied. Larger values represent slower response.
2. **Baud rate:** a unit used to measure the speed of electronic code transmission, equal to one-unit interval per second.
3. **BMS:** Battery Management System
4. **Brake Current Limit:** Sets the maximum RMS regen current during braking when a brake command is given, as a percentage of the controller's full rated current. The full rated current depends on the controller model.
5. **Brake Input Rate:** Sets the rate (in seconds) at which the vehicle slows down when brake is applied or when throttle is applied in the opposite direction. Larger values represent slower response.
6. **Brake Maximum:** Defines the input voltage required to produce 100% braking torque. Decreasing the brake max setting reduces the amount of voltage necessary to produce full braking torque.
7. **Brake Type:** Defines the brake input for the controller:
  - a. **Type 1**= 3 wire 0 to 5kohm pot or electronic 0-5v input or pressure transducer.
  - b. **Type 2**= 2 wire with switch; 0 to 5kohm.
  - c. **Type 3**= switch.
8. **CAN:** Controller Area Network. A vehicle bus standard designed to allow microcontrollers and devices to communicate with each other within a vehicle. All controllers on the CAN bus need to have the Baud Rate set the same.
9. **Creep Torque:** Determines the amount of torque applied to the vehicle at a stop with no throttle input, to emulate the feel of an automatic transmission automobile. **WARNING!** When interlock is engaged, creep torque allows vehicle propulsion if a direction is selected even though no throttle is applied. Care should be taken when setting up this parameter. If pedal braking is enabled, creep torque is progressively disabled as brake is applied so as to prevent the motor from driving into the brakes and thus wasting energy.
10. **DCL:** Discharge Current Limit is transmitted from the Orion BMS AND Orion BMS Jr and is a representation of the maximum current that the battery can discharge at any given time.
11. **Deadband:** is an area of a signal range or band where no action occurs (the system is dead).
12. **EncA & B:** two signals from the encoder for which the controller determines direction of rotation and speed of the motor.
13. **Field Weakening Rate:** Determines the control loop gains for field weakening. Setting the rate too low may create surging in the vehicle as it accelerates at mid to high speeds. Setting the rate too high may create high frequency oscillations (usually audible) when the vehicle accelerates at mid to high speeds.

14. **Generic CAN Message:** CAN message containing general information regarding the status of the motor and controller.
15. **Idle Torque:** Torque load delivered by the motor at idle. If the Idle for the motor is enabled, idle torque will equal creep torque.
16. **Load Meter:** The LED lights that are located on the bottom of the Spyglass represent how much of a load is exerted on the system.
17. **Neutral Braking:** Neutral braking occurs progressively when the throttle is reduced toward the neutral position or when no direction is selected. The neutral braking parameter is adjustable from 0 to 100% of the regen current limit.
18. **Nominal Voltage:** Battery pack voltage; not to exceed controller voltage ratings.
19. **Regenerative Braking:** Regenerative braking is used on electric vehicles to recoup some of the energy lost during stopping. This energy is saved to the batteries and used later to power the motor to put the car in motion.
20. **Shift Neutral Braking:** Adjustment to neutral braking while pressing the clutch to shift a manual transmission
21. **SOC:** State of charge.
22. **Spyglass:** Name given by Curtis Instruments to the 8 segment LCD, 5-LED display.
23. **Throttle Maximum:** Defines the wiper input voltage required to produce 100% controller output. Decreasing the throttle max setting reduces the amount of voltage necessary to produce full controller output.
24. **Throttle Type:** Defines the throttle input for the controller:
  - a. **Type 1**= Electronic without switch
  - b. **Type 2**= 0-5K ohm 2 wire pot with switch.
  - c. **Type 3**= 0-5K ohm 3-wire pot with switch. Electronic with switch.
  - d. **Type 4**= wigwag 3-wire 0-5K ohm, or 0-5v voltage source.