



**620 Magnolia Avenue
Suite B
Ontario, CA 91762
(909) 923-1973**

INSTALLATION INSTRUCTIONS

E-Z-GO Installation Notes

**CURTIS 1232, 1234, 1236 OR 1238
AC INDUCTION MOTOR/ CONTROLLER**

EZ-GO Curtis Controller Installation

1. Disconnect Negative Battery Cable, Disconnect Positive Battery Cable.
2. Disconnect all Motor and Controller wires.
3. Remove original Motor, Controller & Reversing Switch (remove controller-mounting plate, if equipped).
4. Remove original wiring harness. Unplug any connector's possible (cut as little as possible). If equipped with rear brake lights, label and keep factory wires from the brake pedal switch. These wires will be reused to enable the brake lights. (See DIAGRAM 2.1)
5. Install the Controller mounting plate in cart. See PICTURE 1.5. Installation of the cables and wiring harness will be outlined in later steps.
6. Bolt the Controller, ITS Converter & Solenoid to new mounting plate. Use supplied ¼-20 bolts and lock washers.
7. Install new AC 9 Motor. Use the supplied ¼-20 bolts and lock washers. Do not over torque Motor Bolts.
8. If clearance from the passenger shock mount to the motor's fan shield is less than one inch (viewing from the top), cut/trim passenger side rear. This procedure is not needed if cart has been lifted.
9. If equipped, install the on-board Battery Charger. For Delta-Q Battery Charger see Picture 1.6 for reference.
10. Connect Motor Cables from the controller to the AC9 Motor at each appropriate phase. Motor Cables and Battery Cables should be at least #2 AWG. See Picture 1.7 and DIAGRAM 2.4 for reference.
11. Connect one side of the solenoid to the Fuse Post on the Controller.
12. Connect Negative Battery Cable to the controller. (DO NOT connect to Battery at this point).

13. Install Wiring Harness.
14. Use supplied cable adapter for throttle wires. Plug the flat connector into the ITS converter box. Plug 4-pin square connector into mating connector on wiring harness. Connect the Blue wire to the Blue wire on the solenoid, Red to the Red, Green to the Green, White to the White & Black to the Black on the ITS cable.
15. Connect wires to FWD/REV switch, See DIAGRAM 2.2 Connect the Red/Blue wire from Pin 25 to the center connector tab. Connect the Yellow towards "F", forward and White towards "R", reverse.
16. Drill a 2 1/16" hole in the dash panel for the BDI.
17. Plug cable with 8-pin connector into the back of the Dash Display.
18. Connect Red Wire to one side of key switch.
19. Connect Blue wire from Pin 1(KSI) to key switch.
20. Connect a Yellow wire from F & R switch to the positive side of the reverse buzzer, and the Gray wire to the negative. See DIAGRAM 2.2.
21. Connect the Red/Blue wire from Pin 25 to terminal 2 on the Golf/Street switch, and the Brown wire from Pin 12 to terminal 1. (Golf Mode is selected when terminals 1 and 2 are connected together). See DIAGRAM 2.2.
22. For carts equipped with Rear Brake Light Kit, install a 12VDC automotive type relay in a suitable location where both factory and system wires can be connected together. The factory brake wires were disconnected and labeled at step #4. The below connections can be reviewed by using the DIAGRAMS 2.1, 2.3
 - 22.1. Connect the factory +12V source Red wire to the relay at terminal #30.
 - 22.2. Connect the factory Brown wire of the rear brake lights to the Brake Relay at terminal #87. Wire color may be different depending on model year.
 - 22.3. Connect a Blue wire from the key switch to the Brake Relay at terminal #86.
 - 22.4. Connect the Orange wire to the Brake Relay at terminal #85.

- 22.5. Connect Red/Blue wire to the COM on the Brake Switch, Connect the purple wire to the N.C. terminal.
23. Connect White/Red wire to Menu Button. Connect other side of button to Red/Blue wire From Pin 25. See DIAGRAM 2.2.
24. Connect Orange/White wire to the – (negative side of the Main Contactor), and Blue/White wire to the + (positive side). Remove any diode, resistors.
25. Connect Fuse Wire and the + Battery cable to the Main Contactor. If On Board charger is used, connect fuse wire to the Green wire from the charger.
26. Plug in Encoder Cable to the motor.
27. DOUBLE CHECK ALL CONNECTIONS.
28. Secure all wires, harnesses and cables to the cart's frame by using tie straps.
29. Install 10 Amp fuse at the fuse holder in the system harness.
30. Connect – (negative) Battery Cable.
31. Test Cart on Jack Stands. There will be no motor damage if the motor initially over speed. If motor runs slow and in the wrong direction, reverse the U and W leads on the Motor.

Driving the car with the A-C Drive System

When key switch is first turned on, the system needs about 2 seconds to come on-line. After this time has expired, select the desired drive direction at the Forward/Reverse switch and press the accelerator pedal. The drive wheels could be in either direction when first turned on.

BDI: (Dash Gauge), the BDI will display Battery Charge level (LED's at bottom) as well as displayed messages.

<u>BDI Message</u>	<u>Mode</u>
MPH	Cart in Street Mode (displays vehicle speed)
GOLF	Cart in Golf Mode (see note below)
REVERSE	Cart in Reverse direction (see note below)
LOWBATT	Cart in Limp Home mode (see note below)

Menu System:

Battery Percentage:	State of Charge left in batteries.
TOC:	Time on Charge, Time in minutes since the last time the car was charged.
Volts:	Battery Voltage
RPM:	Motor RPM

The last menu option is the vehicle odometer.

Street Mode gives the cart a Max speed of 25 Miles per hour. Acceleration & Regenerative Brake torque are set at maximum level.

When in Golf Mode the cart speed is limited to 12 Miles per hour. Acceleration & Regenerative Brake torque is also reduced.

Drive Mode can be changed on “The Fly”. There is no need to stop the cart when changing from Street to Golf or vice-versa.

When Cart is in Reverse, speed is reduced to 8 Miles per hour. Acceleration & Regenerative Braking torque is also reduced.

Limp Home mode is automatically activated when the Battery charge level has dropped below 20%. The maximum cart speed is restricted up to 15 Miles per hour at Street mode. It is recommended to charge the batteries as soon as possible to prevent damage to the batteries from being over discharged.

Instructions for Throttle Set Up

For systems set up after March 2007 with Version 8.00U software

With Key **OFF**, Select Forward Direction, Release Parking Brake, Press and hold the “Menu” Button, then turn the Key “**ON**”. Hold Menu Button until “Program” appears on the Dash Display, then release.

If the cart has a brake pedal switch:

Use the Brake Pedal to cycle through the options. Have the Golf/Street Mode switch set to “Street Mode”, (MPH), to change parameters.

If the cart does not have a brake pedal switch:

Select “Golf Mode” and press the “Menu Button” to cycle through the options.

To change a parameter in any of the options:

Select “Street Mode” and press the “Menu Button” to change a parameter or activate an option.

T Type: This is the Throttle Pot Type Parameter. For 0-to-5k, 2-wire throttle pots, set to type 3. For 3-wire throttle pots or EZ Go with ITS converter box, set to Type 2. The default is Type 2.

Throttle: This allows the Throttle range to be calibrated.

Cycle the program options to “Throttle” on the Dash Display, select Street Mode, press the Accelerator Pedal to the floor (Max Throttle).

With the pedal pressed, press and hold the “Menu” Button and the display will show “**HoldMenu**”. Maintain the pedal and menu button pressed until the display reads “**Turn OFF**”. After this message is displayed, turn off the Key. DO NOT release the accelerator pedal or the Menu button before turning OFF the Key. The Throttle is now calibrated.

Using this procedure will ensure full throttle range; if this procedure is not performed the calibration will be at to a default setting. Use this set up procedure for 2-wire, 0-to-5k, three wire throttle or EZ Go with ITS converter box types.

Rst: This is the BDI reset voltage per battery cell. Adjust only if there is a problem with the BDI resetting to 100% when the batteries are below 85% and have not been charged or not resetting after a charge.

To increase the parameter, select “Forward” and “Street Mode”, then press the Menu button.

To decrease, select “Reverse” and “Street Mode”, then press the Menu button. The default is 2.125 volts per cell; this should work fine in most applications.

Mode: Sets the Motor Control Mode. The control mode can be set as Mode 1 or Mode 2

Mode 1 is Speed Control. Speed Control means the accelerator pedal controls the actual speed of the vehicle.

For example: In Speed Control Mode if you set the accelerator pedal to half, you will go half speed, uphill, downhill or on flat ground. Speed Mode is great if you are looking for controlled descents down hills and want to use the brakes a little as possible. It does however have more of a jerky feel when changing speeds with the accelerator pedal.

Mode 2 is Torque Control Mode. Torque control is the same type of control method a DC motor has. The accelerator pedal controls the amount of torque the motor produces. This gives a much smoother feel when changing the accelerator position. Brakes will be used more in downhill descents.

Brk%: Only available if the Speed Mode is set to “2”. This sets the amount of Regen when the Brake Pedal is pressed.

To increase the parameter, select “Forward” and “Street Mode”, then press the Menu button. To decrease, select “Reverse” and “Street Mode”, then press the Menu button.

If the default braking level is desired, leave this set to Zero. The Default is 40%. So, setting to 1% would be the lowest setting and give almost no Regen.

Instructions for using On Board Diagnostics

With the Key **OFF**, Select Reverse Direction, Press and hold the “Menu” Button. Turn Key the “**ON**”, hold Menu Button until “Diagnose” appears on the Dash Display, then release the Menu Button. Pressing and releasing the menu button will scroll through the Diagnostic options. The cart can be driven during diagnostic checks.

T Sw: This monitors the state of the Throttle Switch. With the pedal in the idle position the display should read “**OFF**”, when the pedal is pressed the display should change to “**ON**”. If “**OFF**” is always displayed there is a problem with the switch on the throttle pedal. This test can be performed in “Neutral” or with either direction selected.

TPV: This is the raw Throttle pot voltage. This test should be performed with the car in “Neutral”. 0.2 volts is normal for idle position, at full throttle, 3.5 volts for 2 wire pots, and 5.0 volts for 3 wire pots.

T Max: This is what the Max Throttle Voltage Parameter is set at. For example: If the Parameter is set at 4.5, then the TPV will need to reach 4.5 for full speed to be obtained. Use the Throttle calibration procedure if adjustments are necessary.

Req %: This is the amount of throttle being requested of the controller. This should be a number from 0 to 100% when the car is being driven.

Brk: On or Off. Checks to ensure brake switch signal input to the controller. Should be ON when the brake pedal is pressed and OFF when the brake pedal is released.

CapV: This is the voltage on the Capacitor Bank inside the controller. This voltage should be at or near the voltage of the Batteries. When the Throttle is pressed, this sends a signal to the controller to pre-charge the Capacitor Bank and turn the Main Solenoid ON. If this voltage is low or at 0, this means there is probably a failure in the Pre-Charge circuit and the controller will need to be repaired or replaced.

EncA & EncB: These are the Motor Encoder signals shown in RPM. This can be used to troubleshoot either an Encoder failure, or a problem in the Encoder wiring. If the motor turns slow and in the proper direction, check the RPM of both signals. If EncA has no signal, the Display will read Zero. The same applies to EncB. EncA involves with White, (sometimes Brown), wire on the encoder connector, EncB is the Green wire. On an EZGO, these colors are reversed.

Main: This is the state of the Main Contactor, see table below:

0 = Open, Solenoid not turned on.

1 = Pre-charge.

2 = Weld check, the controller is checking for welded contacts.

3 = Closing Delay

5 = Closed, the Solenoid coil is energized and the contacts should be closed (Operational Mode).

6 = Open Delay, after the cart is stopped there is a delay of about 5 seconds for the Solenoid to open.

OS: This is the Version of the Operating System in the controller.

Build: This is the Build number of the Operating System.

Ver: This is the VCL (vehicle control language) version number.

D/C: This is the date when the controller was manufactured. 6123=the 123rd day of 2006

S/N: This is the unique serial number of the controller.

Faults: If any, will be displayed.

Fault Codes

Fault codes will display on the Dash Display when they happen, the “Wrench” on the display will also light up.

Code 12, Controller Over Current

Code 13, Current sensor fault

Code 14, Precharge Failure

Code 16, Controller Over Temperature

Code 17, Severe Undervoltage

Code 18, Severe Overvoltage

Code 25, 5-volt power supply failure

Code 36, Encoder Fault, see diagnose, EncA & EncB.

Code 37, Motor Open or Open Phase on controller fault

Code 38, Main Solenoid welded

Code 39, Main Solenoid not closing

Code 73, Stall detected, No encoder signal, see diagnose, EncA & EncB.

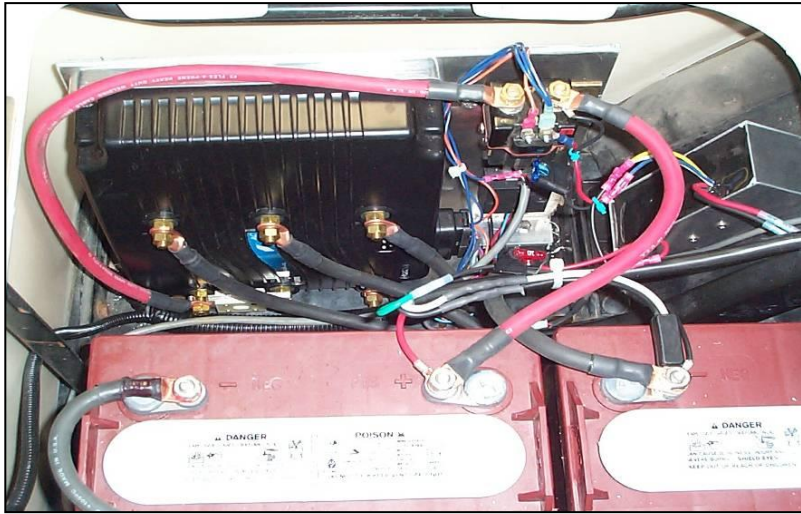

Picture 1.5



Picture 1.6

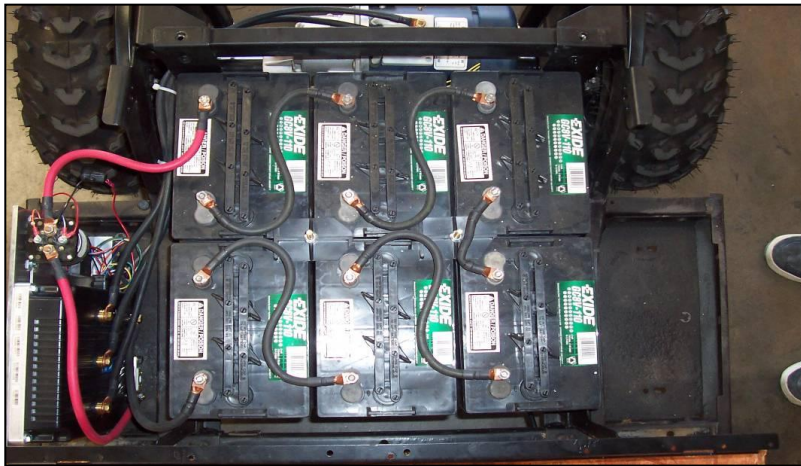

Picture 1.7

BRAKE LIGHT REWIRING RELAY DETAIL -DIAGRAM 2.1

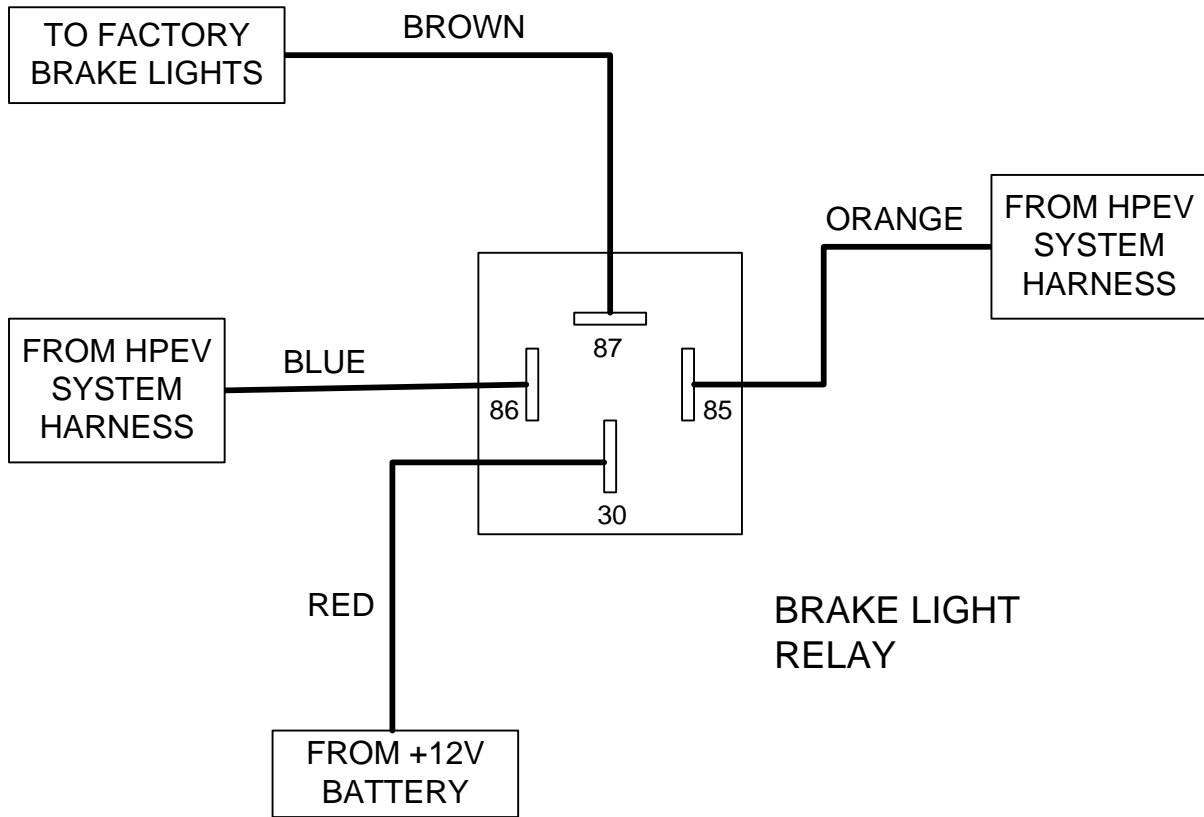

EZ-GO DASH PANEL WIRING DETAIL - DIAGRAM 2.2

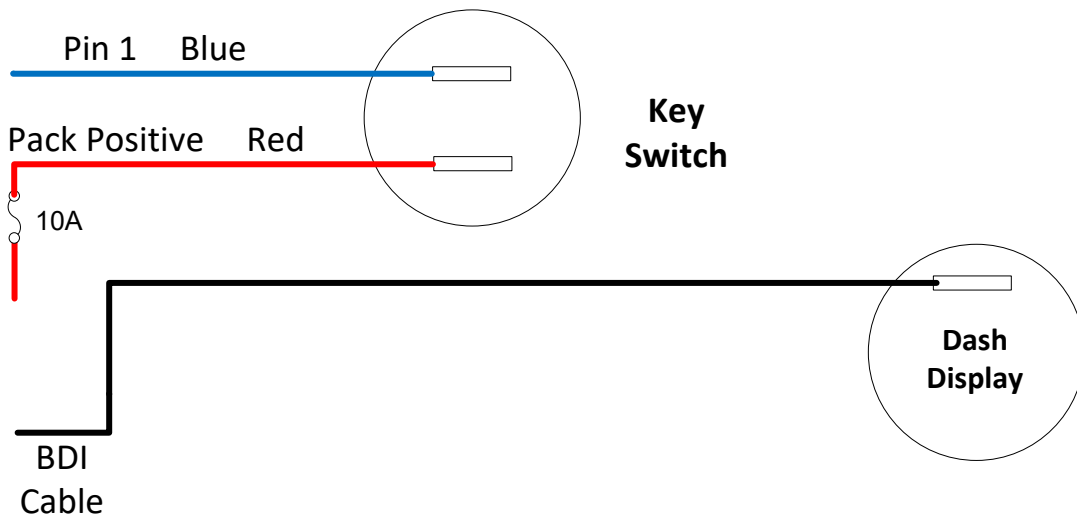
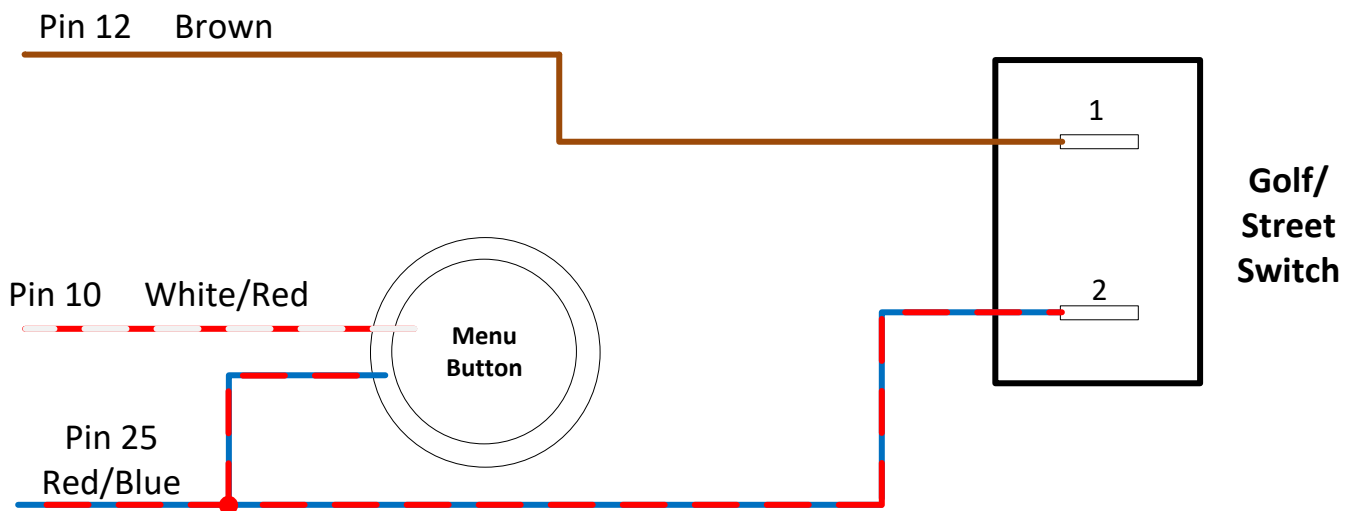
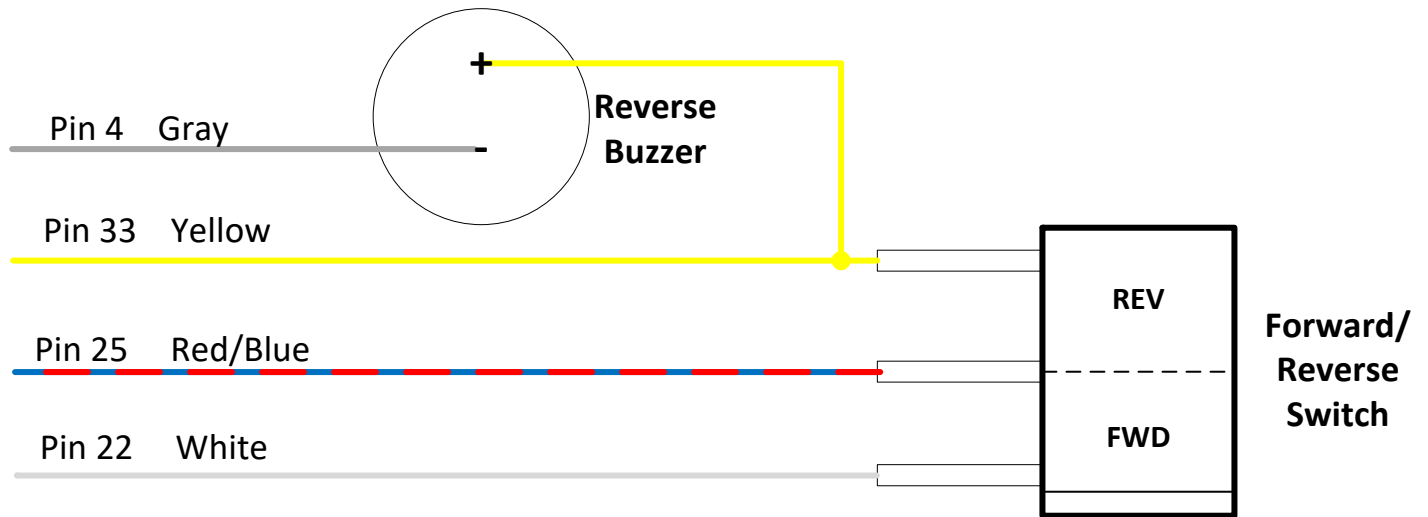

NOTICE: This drawing is the property of Hi Performance Electric Vehicle Systems, Inc., and/or its subsidiaries and affiliates (individually and collectively "HPEVS"), and contains highly proprietary, confidential, and trade secret information of HPEVS. The recipient of this drawing agrees (a) to use the information contained herein for the purpose for which it was furnished by HPEVS (b) to return this drawing upon HPEVS request. This notice shall appear on any complete or partial reproduction of this drawing.

R1
AMP
#776164-1

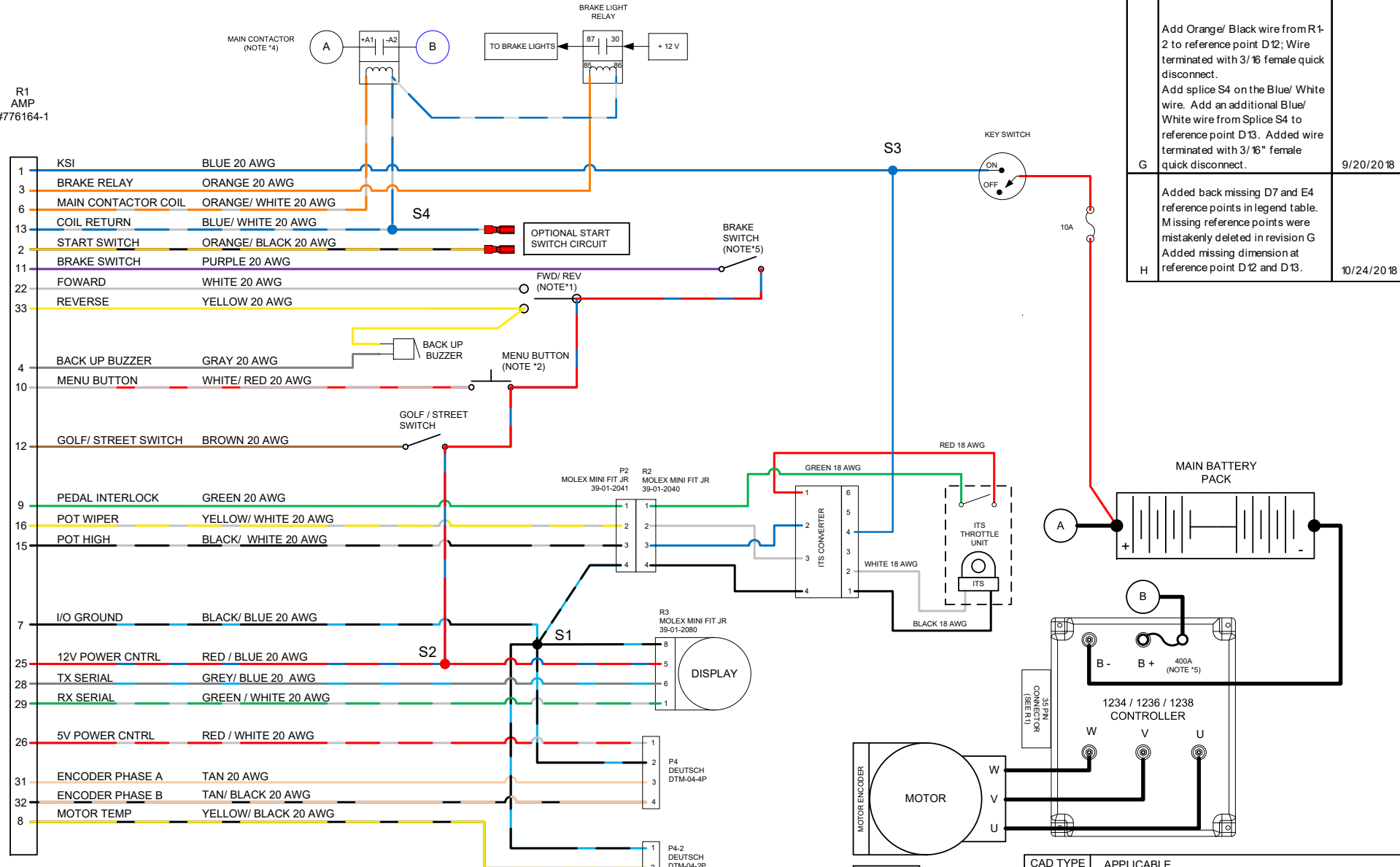

- NOTES:
- (*1) IF REVERSE IS NOT USED, CONNECT WHITE WIRE TO BLUE WIRE.
 - (*2) MENU BUTTON IS OPTIONAL USE WITH DISPLAY.
 - (*3) REMOVE ANY DIODES OR RESISTOR FROM MAIN CONTACTOR.
 - (*4) USE 400A FUSE IN 650 SYSTEM. USE 300A FUSE IN 350 SYSTEM.
 - (*5) NORMALLY OPEN. CONTACTS MUST BE CLOSED WHEN BRAKE PEDAL IS PRESSED.

REVISIONS		
REV	DESCRIPTION	APPROVED
G	Add Orange/ Black wire from R1-2 to reference point D12; Wire terminated with 3/16 female quick disconnect. Add splice S4 on the Blue/ White wire. Add an additional Blue/ White wire from Splice S4 to reference point D13. Added wire terminated with 3/16" female quick disconnect.	9/20/2018
H	Added back missing D7 and E4 reference points in legend table. Missing reference points were mistakenly deleted in revision G Added missing dimension at reference point D12 and D13.	10/24/2018

CAD TYPE	APPLICABLE SOFTWARE
VISIO	1010-EZ-GO
UNIT NONE	DRAWING
DRW SIZE A	TITLE
DATE	10/24/18
SCALE 1:1	SUPPLIER PART HW-1010EZGO-HPG
SHEET 1 OF 1	REVISION H
HPEVS	

HIGH CURRENT WIRING DETAIL - DIAGRAM 2.4

